

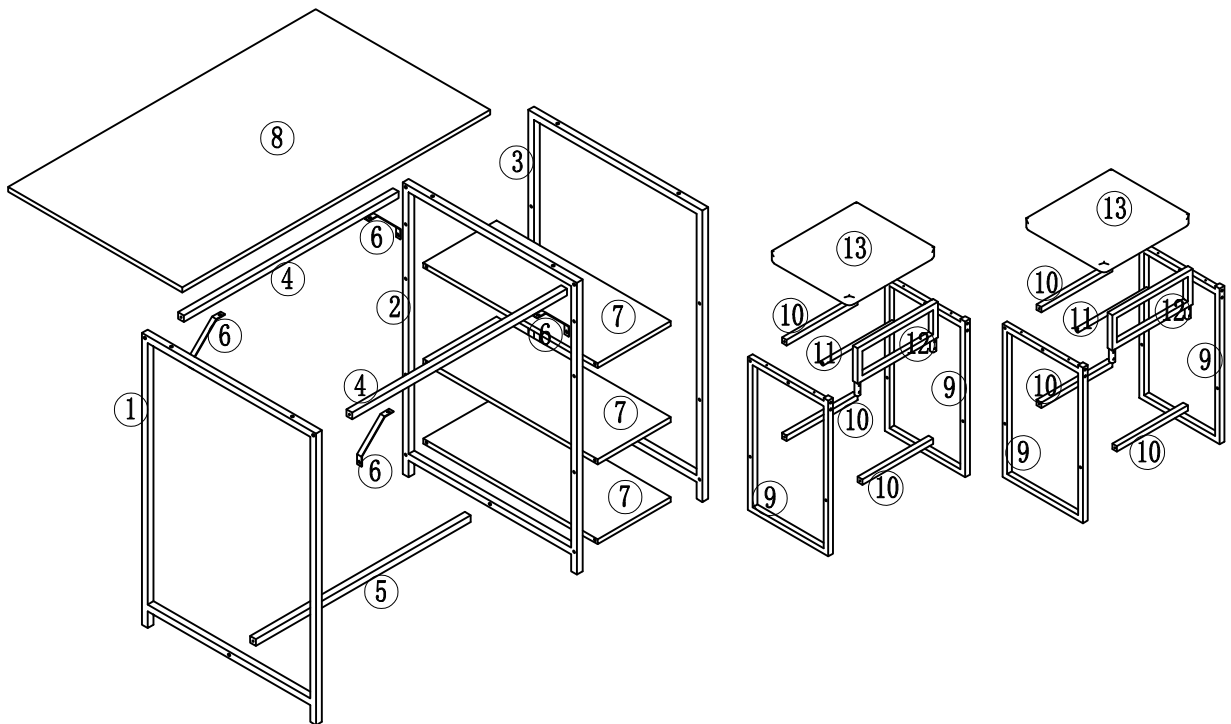

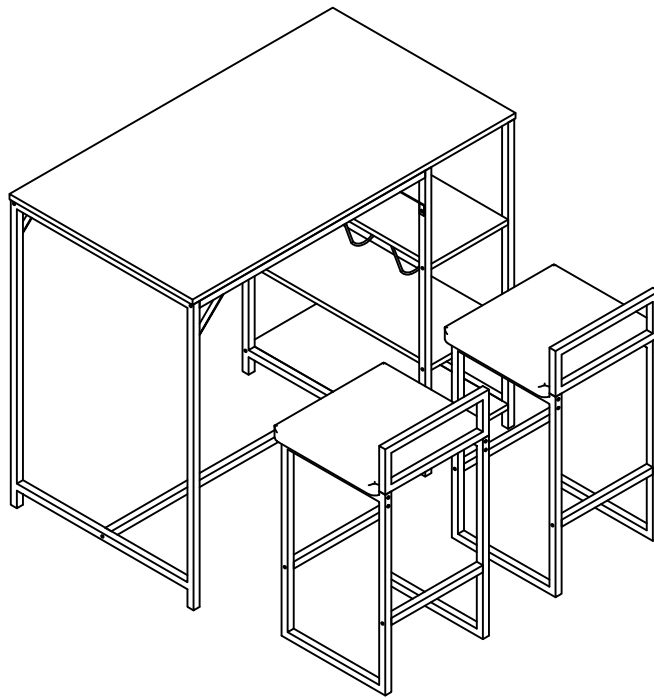

ASSEMBLY INSTRUCTIONS

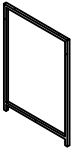

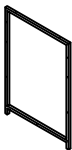
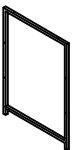
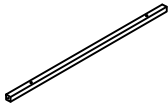

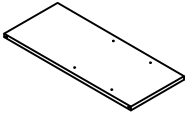
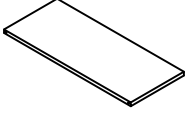
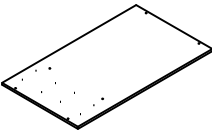
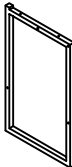

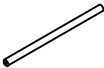
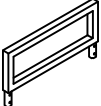
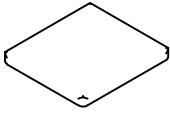



SKU: WF212868



Part List

| | | | | |
|---|---|---|--|---|
|  |  |  |  |  |
| ① x1Pc | ② x1Pc | ③ x1Pc | ④ x2Pcs | ⑤ x1Pc |
|  |  |  |  |  |
| ⑥ x4Pcs | ⑦ x1Pcs | ⑧ x2Pcs | ⑨ x1Pc | ⑩ x4Pcs |
|  |  |  |  | |
| ⑪ x6Pcs | ⑫ x2Pcs | ⑬ x2Pcs | ⑭ x2Pcs | |

Hardware List

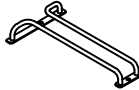
| | | | | | |
|---|---|---|---|---|---|
|  |  |  |  |  |  |
| M6x35 | M6x30 | M6x20 | M6 | | M6x10 |
| Ax22Pcs | Bx18Pcs | Cx8Pcs | Dx6Pcs | Ex1Pc | Fx8Pcs |
|  |  |  |  |  | |
| M4x30 | Hx1Pc | M4x14 | Kx2Pcs | Mx4Pcs | |
| Gx8Pcs | | Jx12Pcs | | | |

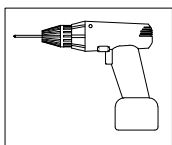

PLEASE BE CAREFUL. DO NOT DAMAGE THE HOLE POSITION WHEN YOU USE POWER TOOLS !

Step 1



M6

Dx6Pcs

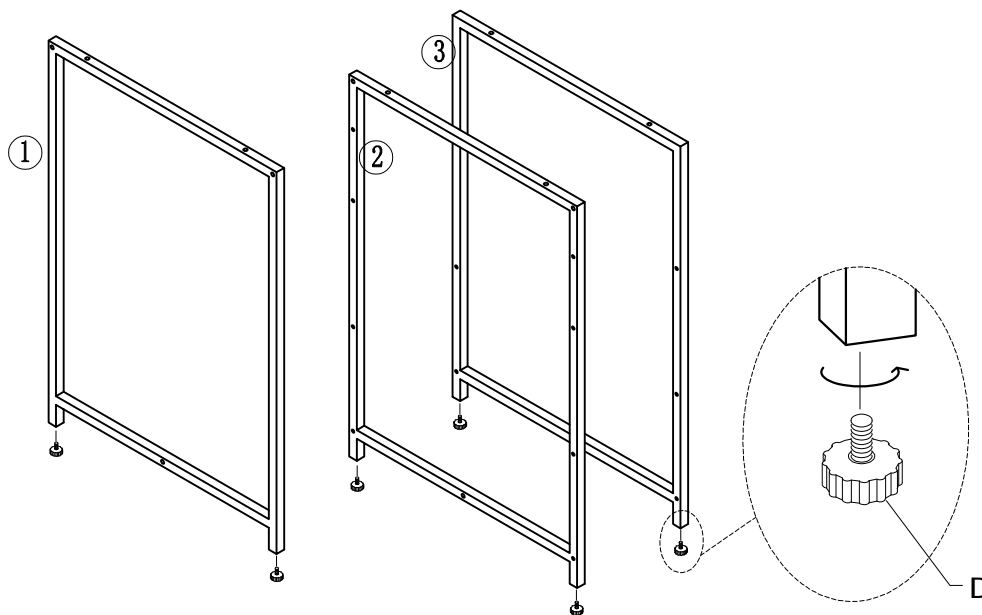

Step 2

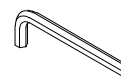

Ex1Pc



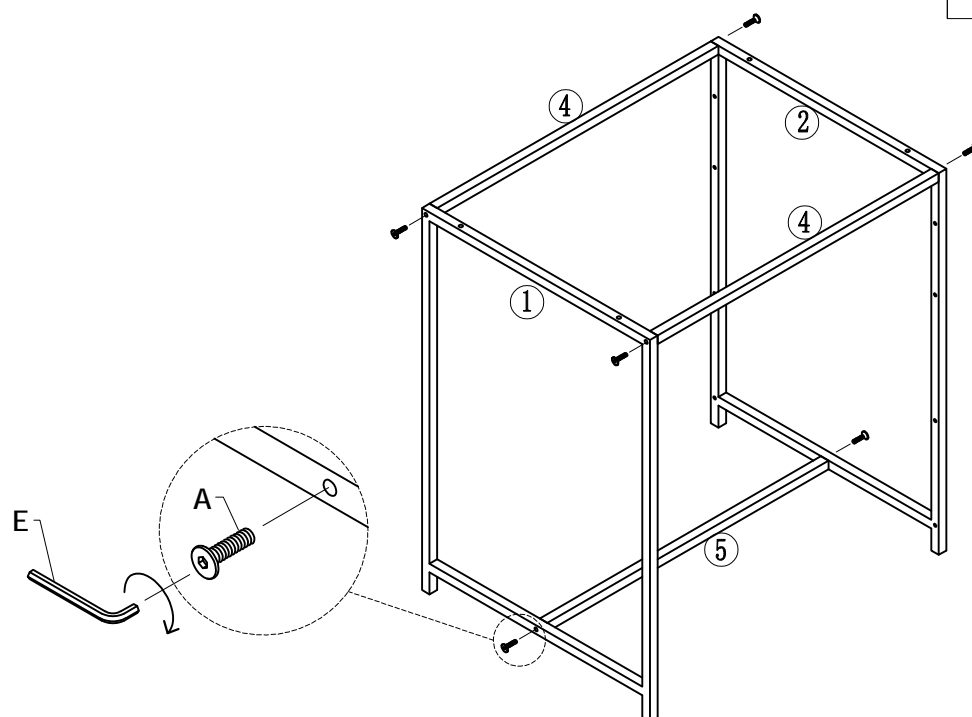

M6x35

Ax6Pcs



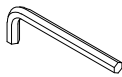

Step 3

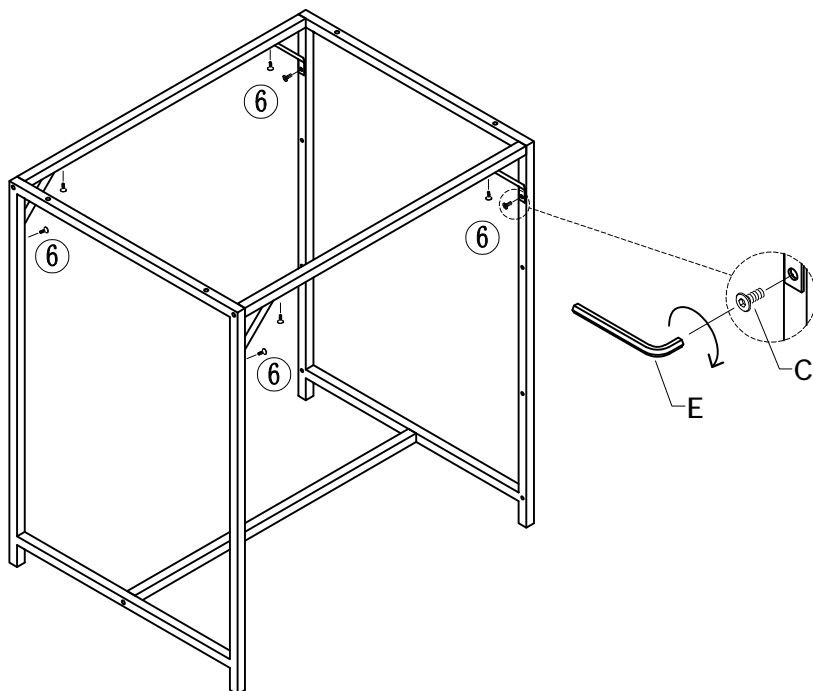
| | |
|---|---|
|  |  |
| Ex1Pc | M6x20 Cx8Pcs |



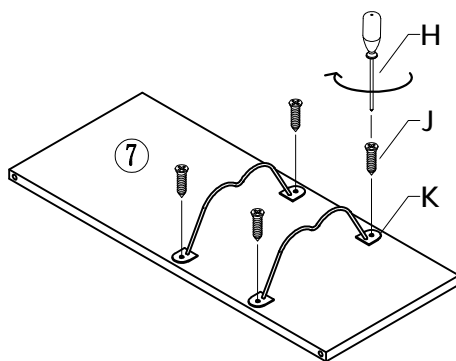

Step 4

| | | |
|---|---|---|
|  |  |  |
| Hx1Pc | M4x14 Jx4Pcs | Kx2Pcs |



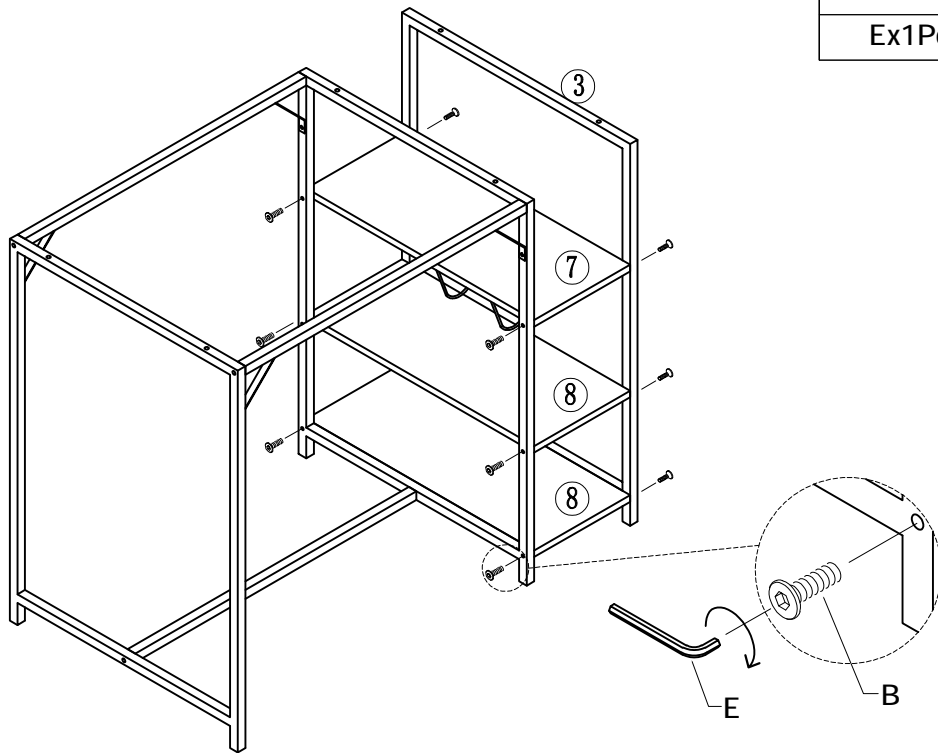

Step 5

| | |
|---|---|
|  |  |
| Ex1Pc | M6x30 |
| | Bx12Pcs |



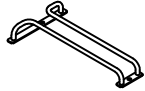

Step 6

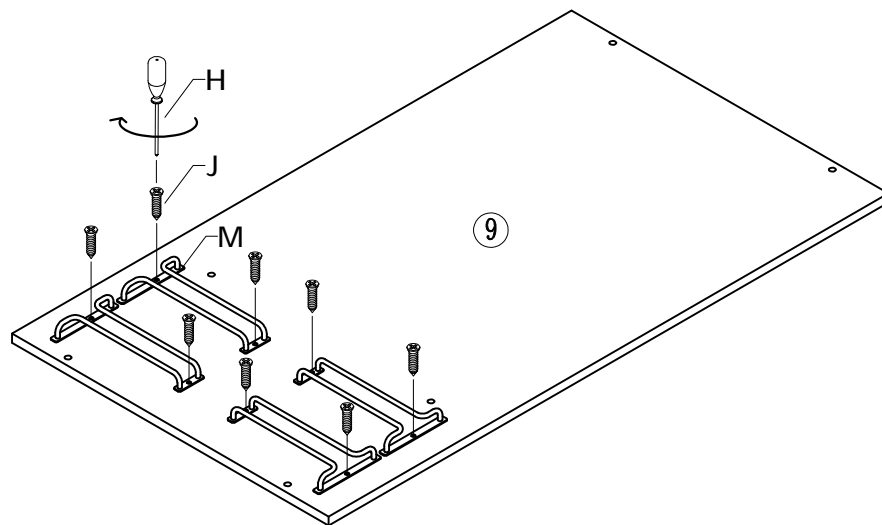
| | | |
|---|---|---|
|  |  |  |
| Hx1Pc | M4x14 | Mx4Pcs |



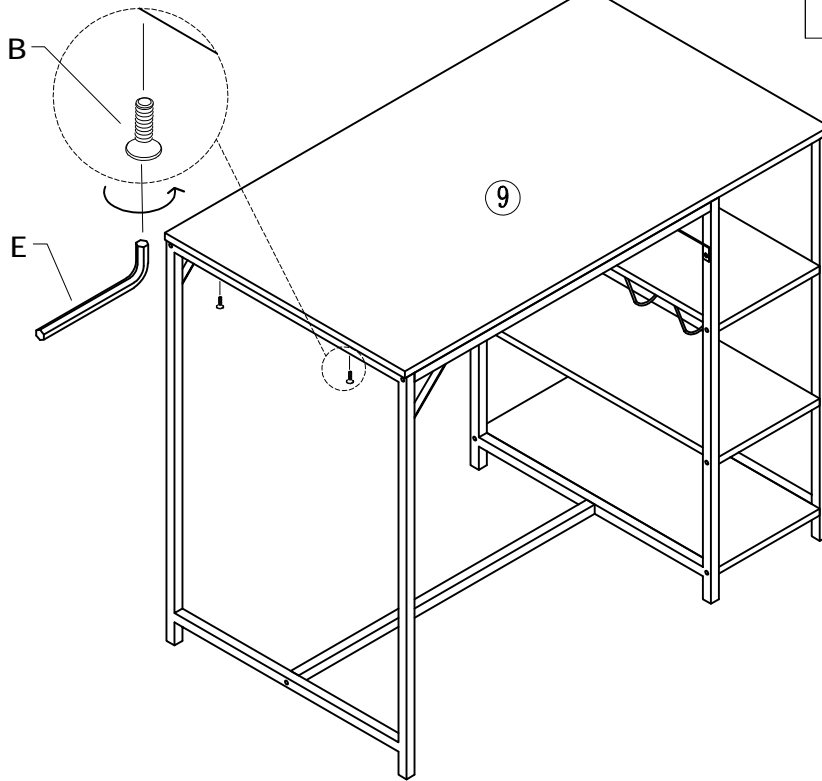

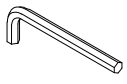
Step 7

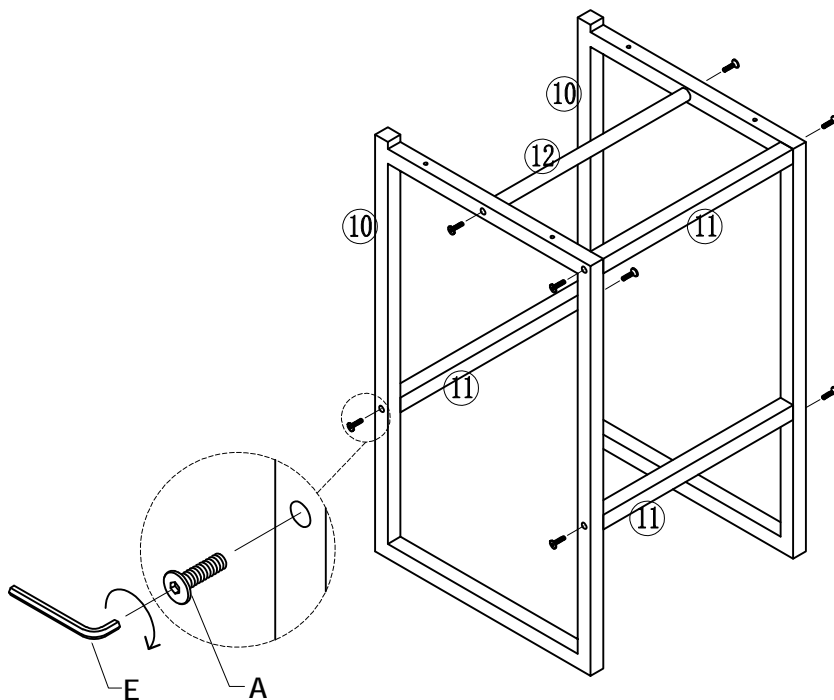

| | |
|---|---|
|  |  |
| Ex1Pc | M6x30 Bx6Pcs |

Step 8

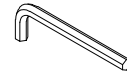

| | |
|---|---|
|  |  |
| Ex1Pc | M6x35 Ax16Pcs |

× 2

Step 9

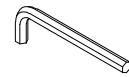

Ex1Pc



M6x10

Fx8Pcs

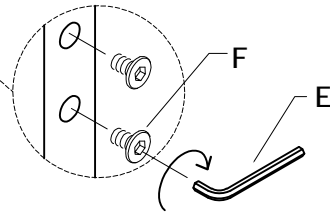
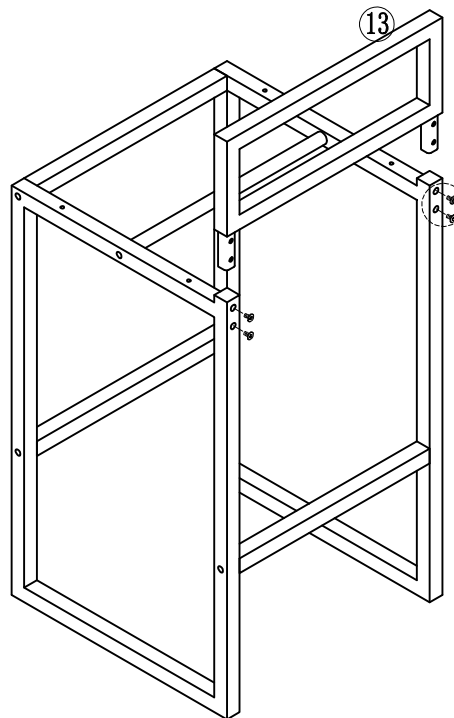

× 2

Step 10



Hx1Pc



M4x30

Gx8Pcs

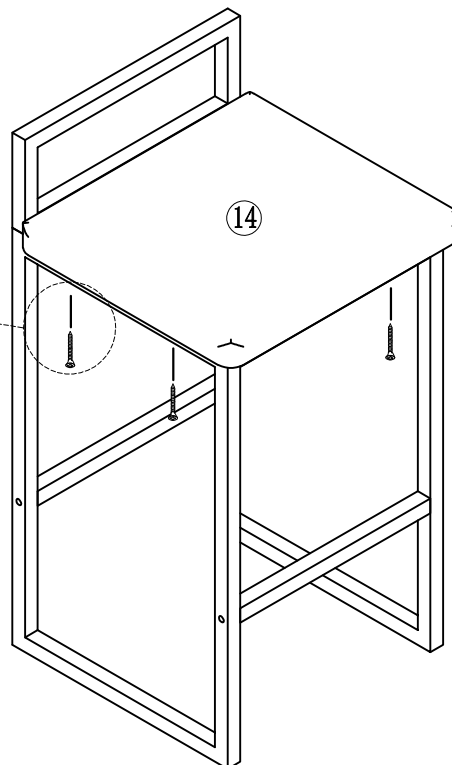
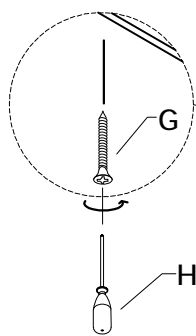

× 2