

Swing Set & Slide & Basketball Hoop *User Manual*

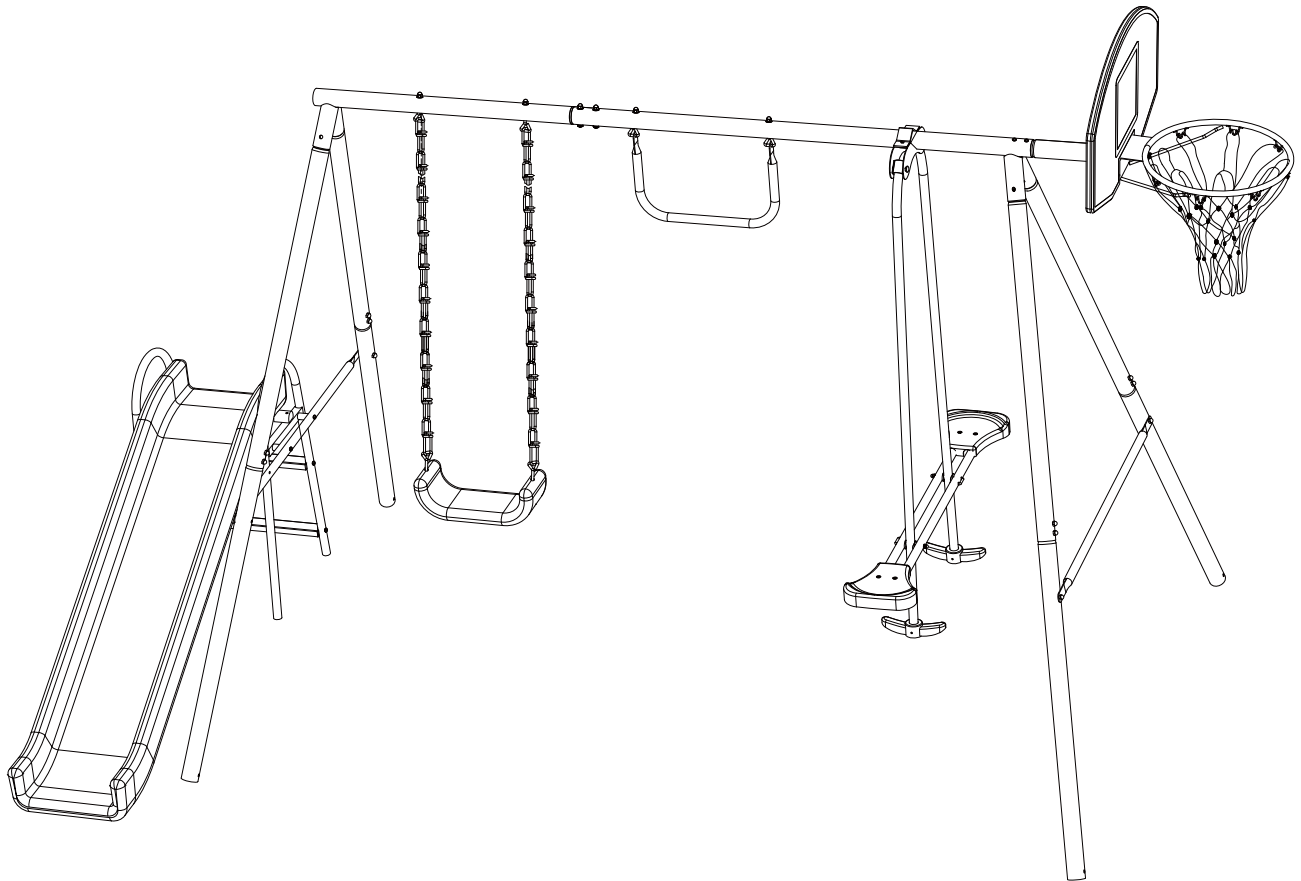

- Warning -

- This swing set is for family domestic use only.
- This swing set is designed for use by children 3-8 years of age weighing no more than 100lbs each
- This swing set is for outdoor use only.
- Children of all ages must be supervised by an adult at all times when using this swing set.
- Adult assembly of this swing set is required. Two adults are recommended for assembly.



WARNING

Please read this instruction manual before you start with the assembly or use this swing set. You must follow all safety instructions while using this equipment; Be absolutely sure that the surface, on which this swing set is set up on, is properly surfaced with fine sand, wood chips or double shredded bark mulch. Do not use this swing set on hard pack soil, concrete or any kind of hard surface. Read all cautionary statement before using this equipment.

PLEASE DO NOT RETURN TO STORE



**Please do not return this product to the retailer!!
We are able to assist you in ANY way**

If you find that you have any trouble with assembly or missing or damaged parts please contact the seller.

OBSERVING THE FOLLOWING SAFETY PRECAUTIONS AND WARNINGS REDUCES THE LIKELIHOOD OF SERIOUS OR FATAL INJURY.

- Read this manual and follow all instructions before using and assembling your playground equipment.
- This playground equipment must be assembled and disassembled by an adult. It is recommended to have two adults assemble this playground equipment.
- Always provide on-site adult supervision for children of all ages at all times.
- This playground equipment is designed to be used by no more than 6 children between the ages of 3 to 8 years at any one time. Children should not weigh more than 100 lbs (45.45 Kg.) each.
- **WARNING:** Lawn swings (if applicable) are designed for use by children over two years of age. Use by children under the age of two can result in entrapment between the seat and back areas. **NEVER** place children in rear facing position or with legs between the seat and backrest because the child's body may pass through the opening causing entrapment of the child's head.
- Always ensure the playground equipment sits on level ground!
- To prevent serious injury to children, the playground equipment must not be used until properly assembled and anchored.
- Do anchor all playground equipment. Do not install over concrete, asphalt, gravel on any hard surface. A fall onto a hard surface can result in serious injury to the user.
- It is recommended that the playground equipment be placed in concrete. Be certain that all anchoring devices (including concrete) are placed below the level of the playing surface or below ground level to prevent tripping.
- Do not assemble or place playground equipment near any obstruction or sharp objects! Place playground equipment on level ground, not less than 6ft (1.8m) from any structures or obstacles such as fence, garage, shed house, overhanging branches, laundry line, electrical wires.
- Do not let children use the playground equipment until it is properly assembled and anchored.
- Provide proper surface material cover for this equipment prior to using this equipment. See page 4 of this manual for more information.
- If any bolts & nuts are missing, do not use this playground equipment!
- If the child has any physical condition that may affect his/her ability to use this equipment, one shall consult a physician, before allowing the child to use this equipment.
- Do not allow reckless playing, such as jumping off swing, slide, or glide ride.
- Do not allow more than one child to play on the swing, trapeze bar or slide at any one time. Children must take turns using the slide.
- Do not allow children over the weight limit to use this equipment. Adults should never ride on any of the swing seats, trapeze or slide.
- Dress children appropriately while on and around this equipment. (Do not allow children to wear ponchos, scarves, jewelry or any other loose fitting clothing that is potentially hazardous while using playground equipment).
- Instruct children not to use the equipment in any manner other than intended.
- Teach children to sit in the centre of the swing play items, with their full weight in the centre of the seats. Do not allow children to stand on the seats. One child per seat only! Do not allow children to lean to the side when riding on other rides, structural members or collide with other playmates.
- Instruct children not to walk too closely in front of, behind, or between moving items.
- Instruct children to keep a safe distance away to avoid being struck by items in play.
- Instruct children not to twist swing chains or ropes or loop them over the top support bar since this may reduce the strength of the chain or rope and may result in failure.
- Instruct children to avoid swinging empty play items. These may strike other children or come back and strike you.
- Instruct children not to get off equipment while it is in motion. Do not allow children to jump from moving play items.
- Do not allow children to swing play items more than 60 degrees.
- Do not allow children to climb or play on equipment when equipment is wet. Slip or falls may occur.
- Check the openings between rollers and sliding surfaces of roller slides for foreign materials that could be potentially hazardous to users.
- Verify that suspended climbing ropes, chain, or cable are secured at both ends, and verify that suspended climbing ropes, chain, or cable cannot be looped back on itself.
- Instruct children not to attach items to the playground equipment that are not specifically designed for use with the equipment such as but not limited to jump ropes, clothesline, pet leashes, cables and chain as they

may cause a strangulation hazard.

- Instruct children not to go down slide head first.
- Check slide bed for extreme heat before letting children use slide (When exposed to direct sunlight)
- Do not allow children to climb on swing from structural members (Legs, top bar and chin bar). These are structural components only and NOT play features.
- Do ensure that all nuts and bolts are completely tightened after assembling the playground equipment.
- Dispose of all packaging properly after unit has been assembled.
- Please retain the instruction manual for future reference and review each season.

CARE & MAINTENANCE INSTRUCTION

It is important to perform the following maintenance inspections at the beginning of each season and twice monthly thereafter.

- * Inspect all nuts and bolts for tightness and tighten as required. It is particularly important that this procedure be followed at the beginning of each season.
- * Remove plastic swing seats slide and take indoors or do not use when temperature drops below 32°F (0° C).
- * Inspect swing seats, ropes, cables and chains for evidence of deterioration. Replace as needed.
- * Inspect all coverings for bolts and sharp edges to be certain they are in place. Replace when necessary.
- * Oil all metallic moving parts monthly during the usage period.
- * Inspect metal tubing and slide bed for damage and sharp edges. Replace when necessary.
- * Sand rusted areas on metal tubing and repaint using a nonlead-based paint meeting the requirements of Title 16 CFR Part 1303.
- * If slide bed is exposed to direct sunlight, always check bed to ensure it is not too hot for children use. Pour cold water onto the slide bed until it cools. Inspect slide bed periodically during use. Replace when necessary.
- * Plastic components should be replaced every three years.

DISPOSAL INSTRUCTIONS

- * When it is time to dispose of the playground equipment, please use care when disassembling the playground equipment. Dispose in a safe place and manner so as not to present any hazards to any individual. Wear heavy duty working gloves!
- * Be sure to completely disassemble the whole swing and slide sets, before disposal.
- * Do not leave partially disassembled equipment in area where accessible by children.
- * Consumer may wish to recycle the steel tubing, please take the frame to your local recycling centre.
- * All plastic part could be recycled, take it to your local recycling centre.
- * Do not let children play with any disassembled parts destined for disposal, such as chain, slide, tubings, bolts, nuts, screws!!

IMPORTANT CONSUMER INFORMATION SHEET

The Consumer Product Safety Commission estimates that about 200,000 injuries occurred from falls from playground equipment; which requires hospital emergency treatment. Injuries from falling tend to be the most serious of all playground injury, and it may be potentially fatal; especially when it is a head injury. The ground surface under the playground equipment can be an important factor in determining the injury causing potential of a fall. A fall onto a shock absorbing surface is less likely to cause serious injury in comparison to a fall onto a non shock absorbing hard surface. Never place playground equipment on hard surface such as concrete, asphalt, rocks, grass may appear to be acceptable, but in heavy traffic area, it may quickly turn into hard packed earth. Fine sand, wood chips, shredded bark are acceptable shock absorbing surface, when installed at a sufficient depth under the playground equipment, it must be maintained properly under and around the perimeter of playground equipment.

Table below lists the maximum height from which a child would not be expected to sustain a life-threatening injury to the head, when falling onto the loose fill surface materials, provided that these materials are installed and maintained at 6, 9 and 12 inches deep. However, consumers should recognize that no matter what type of surface material is used, it can not prevent all injuries due to falls.

**FALL HEIGHT IN FEET FROM WHICH
A LIFE THREATENING HEAD INJURY WOULD NOT BE EXPECTED**

MATERIAL	6 INCH DEPTH	9 INCH DEPTH	12 INCH DEPTH
Double shredded bark mulch	6	10	11
Wood Chips	6	7	12
Fine Sand	5	5	9

We recommend that surfacing material as per table above should extend a minimum of 6ft in all direction from the perimeter of the playground equipment. In certain cases, a child may deliberately jump from a moving swing. Therefore, any shock absorbing material should extend in the front and rear of swing a minimum of 2 times the height of the pivot point; this height is determined by measuring from a point directly beneath the pivot on the supporting structure.

Please note this information is intended to assist in comparing the relative shock-absorbing properties of various materials. No particular material is recommended over another. Every material is only effective when properly maintained. Material should be maintained and replenished periodically after inspection by user, to maintain the correct depth necessary for your equipment.

Note: The maximum fall height for this product is 6 feet. The minimum ground clearance between the bottom of the suspended plays and the playing or ground service must be 8 inches.

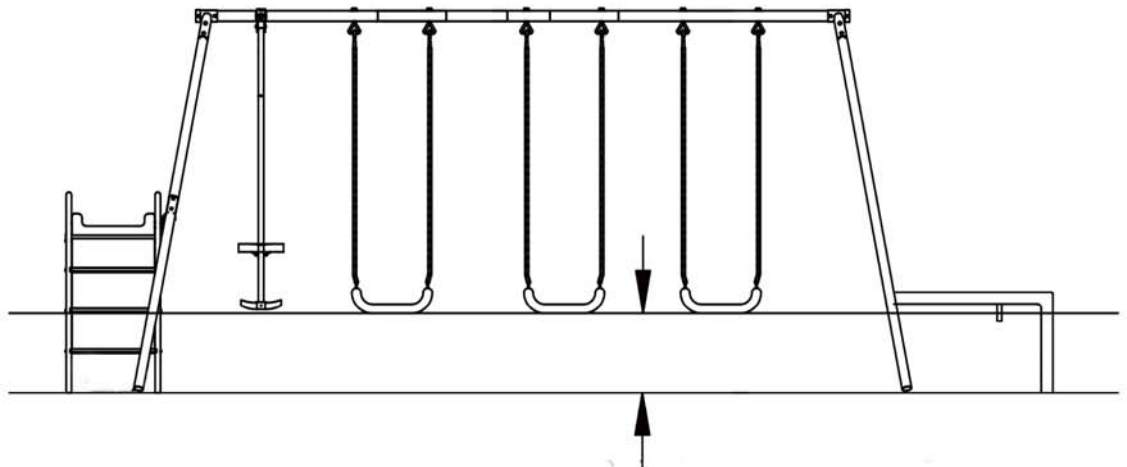

PARTS LIST

Please prepare the following tools prior to assembling this equipment: A socket set or open ended spanner may aid in assembly(not supplied)

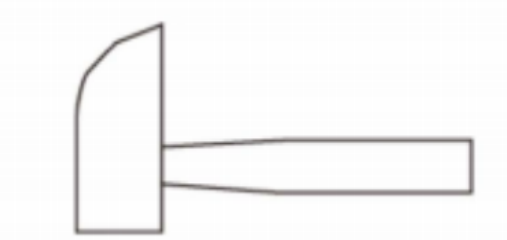

Hammer
(If you intend to install
Anchor, this is needed.
Not included)

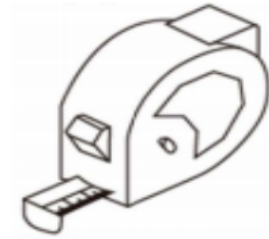

Tape Measure
(Not included)

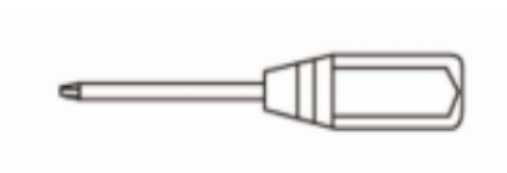

Head Screwdriver
(Not included)

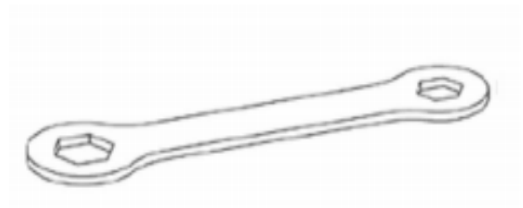











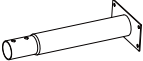

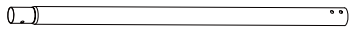
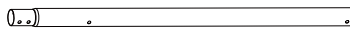
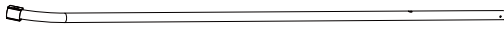
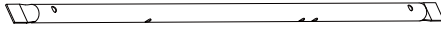

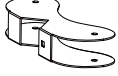

Wrench
(included)

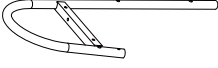













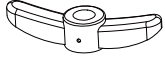









Allen Wrench
(included)

Part List-A

1	Long Top Bar		1
2	Left Top Bar		1
3	Backboard Bar		1
4	Cross Bar (Two Holes)		1
5	Cross Bar		1
6	Top Section Leg		4
7	Bottom Section Leg		4
8	Section Hanger		2
9	Glide Seat Support		2
10	Bracket Clamp		1
11	Bracket		1
12	Horizontal Bar		1
13	Backboard		1
14	Rim		1
15	Net		1
16	Slide Support		2
17	Slide Leg Tube		2
18	Slide Ladder Steps		2
19	Slide Top Support Bar		1
20	CHAIN		2
21	SWING SEAT		1

Part List-B

22	Glide Seat		2
23	Slide		1
24	Plastic Connector (white)		2
25	Hook		4
26	Footrest		2
27	Large Nylon Bearing		4
A	Bolt, Washer M8*63		18
B	Bolt, Washer M8*25		2
C	Bolt, Washer M6*45		2
D	Bolt, Washer M8*25		2
E	Bolt, Washer M6*25		4
F	Bolt, Washer M6*35		4
G	J-Bolt		2
H	Bolt, Washer M5*20		4
I	Bolt, Washer M6*90		2
J	Bolt, Washer M6*35		6
K	Bolt, Washer M6*100		2
L	Bolt, Washer M6*60		2
M	Plastic Cap		24
N	Nut		6
O	Washer		6
P	Wrench		1
Q	Allen Wrench		1

ASSEMBLY INSTRUCTION

- ✧ Place the playground equipment on level ground, not less than 6 ft (1.8 m) from any structure or obstruction such as a fence, garage, house, overhanging branches, laundry lines, or electrical wires.
- ✧ Do not install the playground equipment over concrete, asphalt, packed earth, or any other hard surface. A fall onto a hard surface can result in serious injury to the user.

TIGHTENING NUTS & BOLTS

- * Do not over-tighten the nuts and bolts when you are assembling your playground equipment. This will allow for some possible adjustments and ease of installation.
- * Once you have finished the assembly of the playground assembly, go back over all of the nuts and bolts and properly tighten all of them before using the playground equipment.

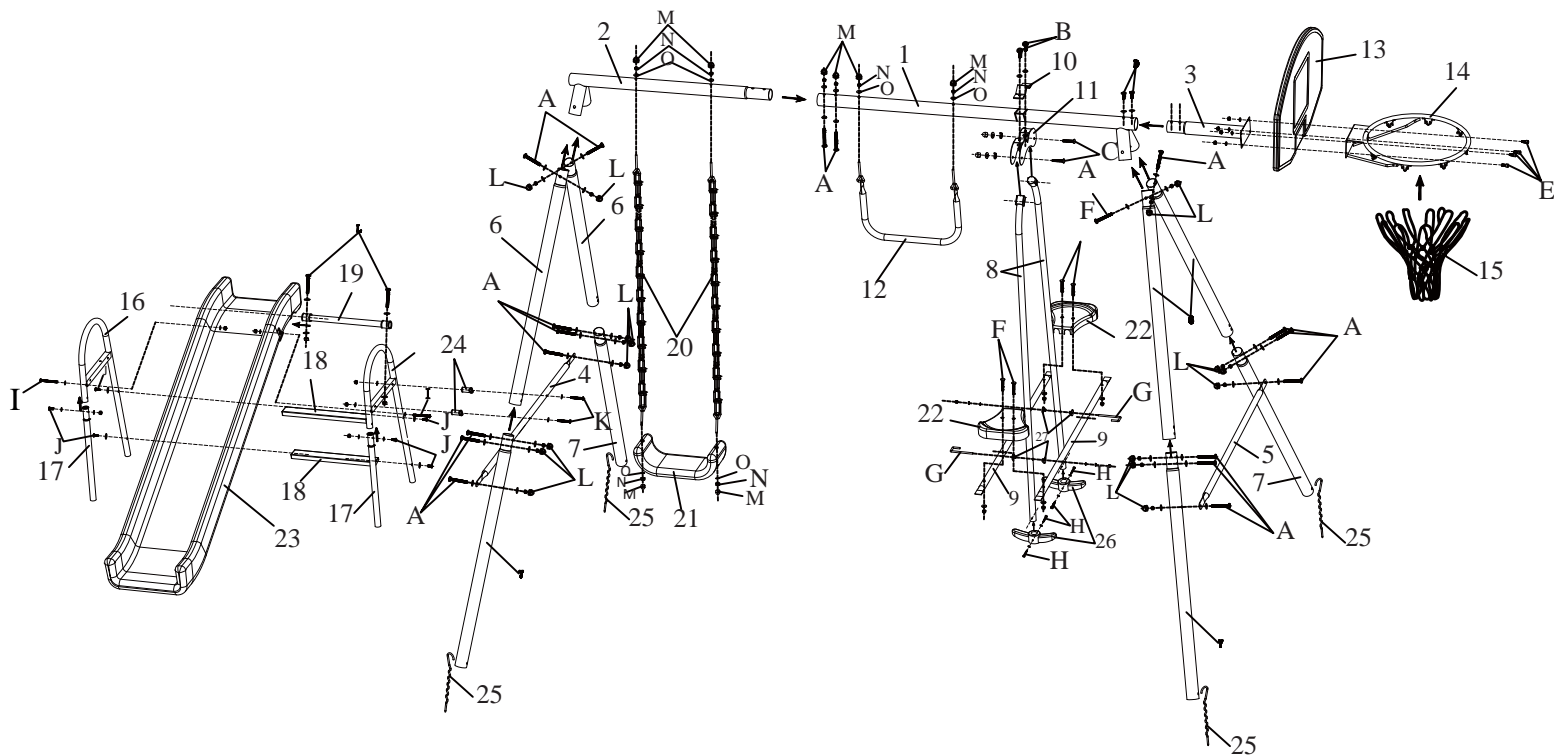

Step 1

Insert Left Top Bar (#2) into Long Top bar (#1), secure with M8*63 Bolt, Washer (#A) and Plastic Caps (#M).

Note: Please make sure the sockets on the bar are facing downwards.

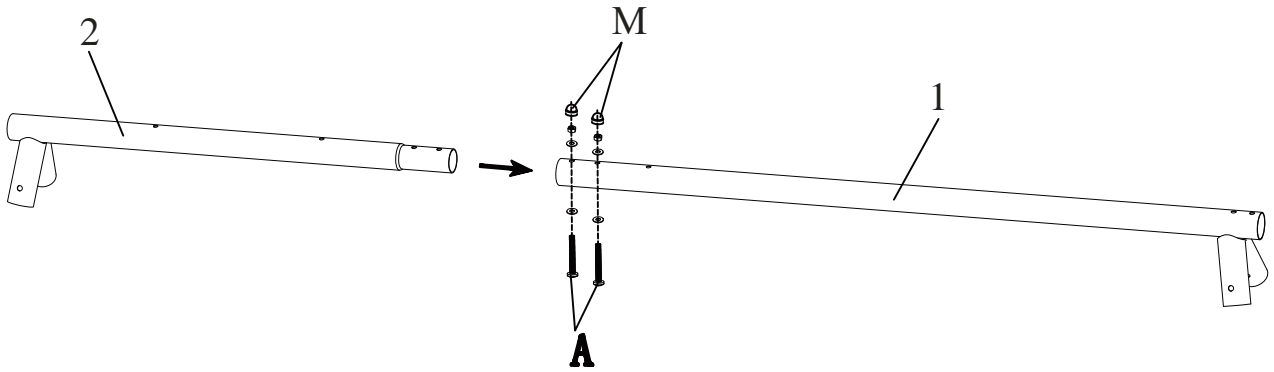

Step 2

Insert Backboard Bar (#3) into the other end of Long Top Bar (#1), secure with two M8*25 Bolts, Washers (#D).

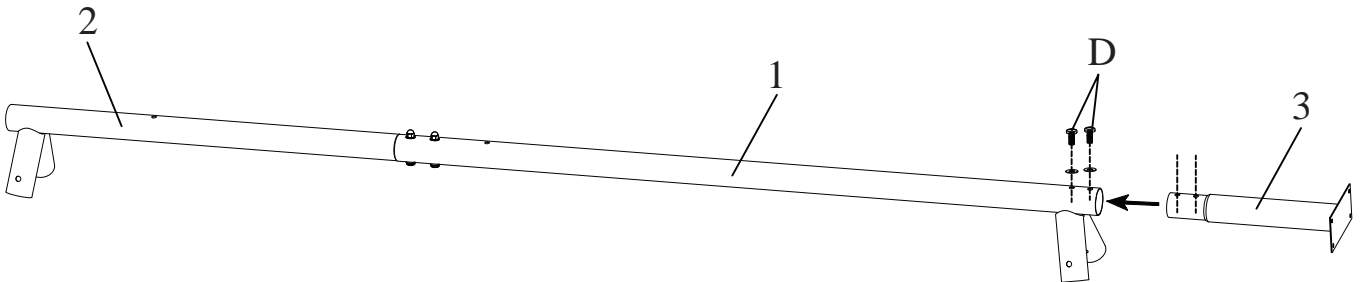

Step 3

Attach the Basketball Rim (#14) to the front slot on the Backboard (#13), and secure them on the front of Backboard Bar (#3) with four M6*25 Bolts, Washers (#E).

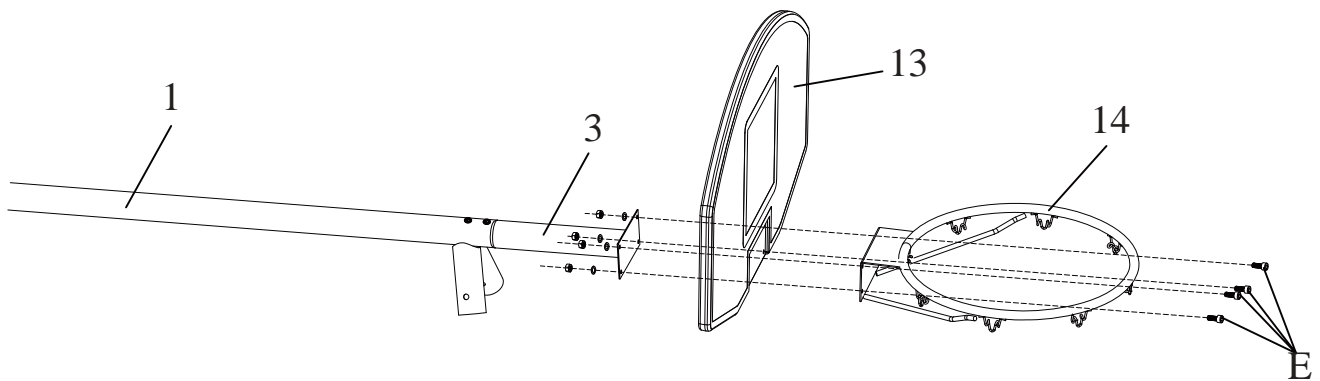

Step 4

Attach the Net (#15) to the hooks on the Rim (#14).

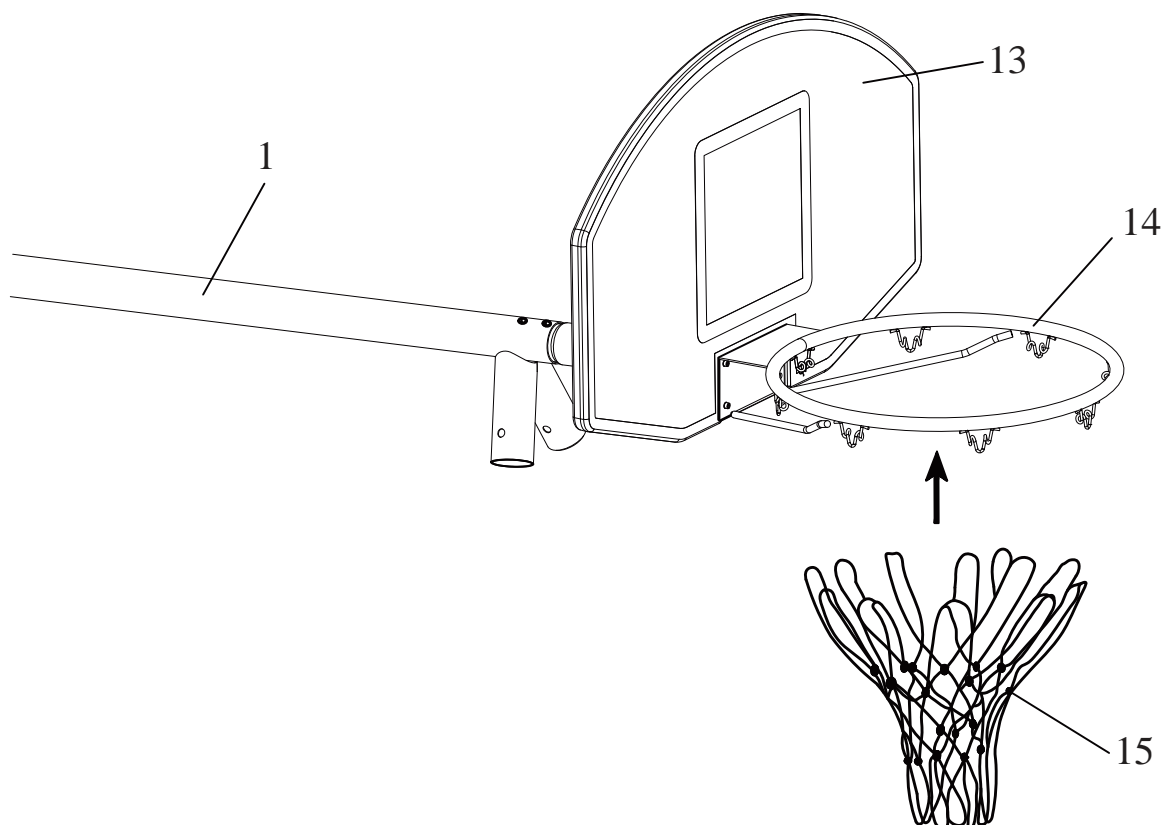

Step 5

- Insert the smaller end of Top Section Leg (#6) into the socket of Left Top Bar (#2).
- Align the hole and secure with M8*63 Bolt, Washer (#A) and Plastic Caps (#M).
- Repeat this step for the other leg on the Left Top Bar (#2).
- Then insert the two remaining Top Section Legs (#6) into the sockets of Long Top Bar (#1), and secure with two sets of M8*63 Bolt & Washer (#A) and Plastic Caps (#M).

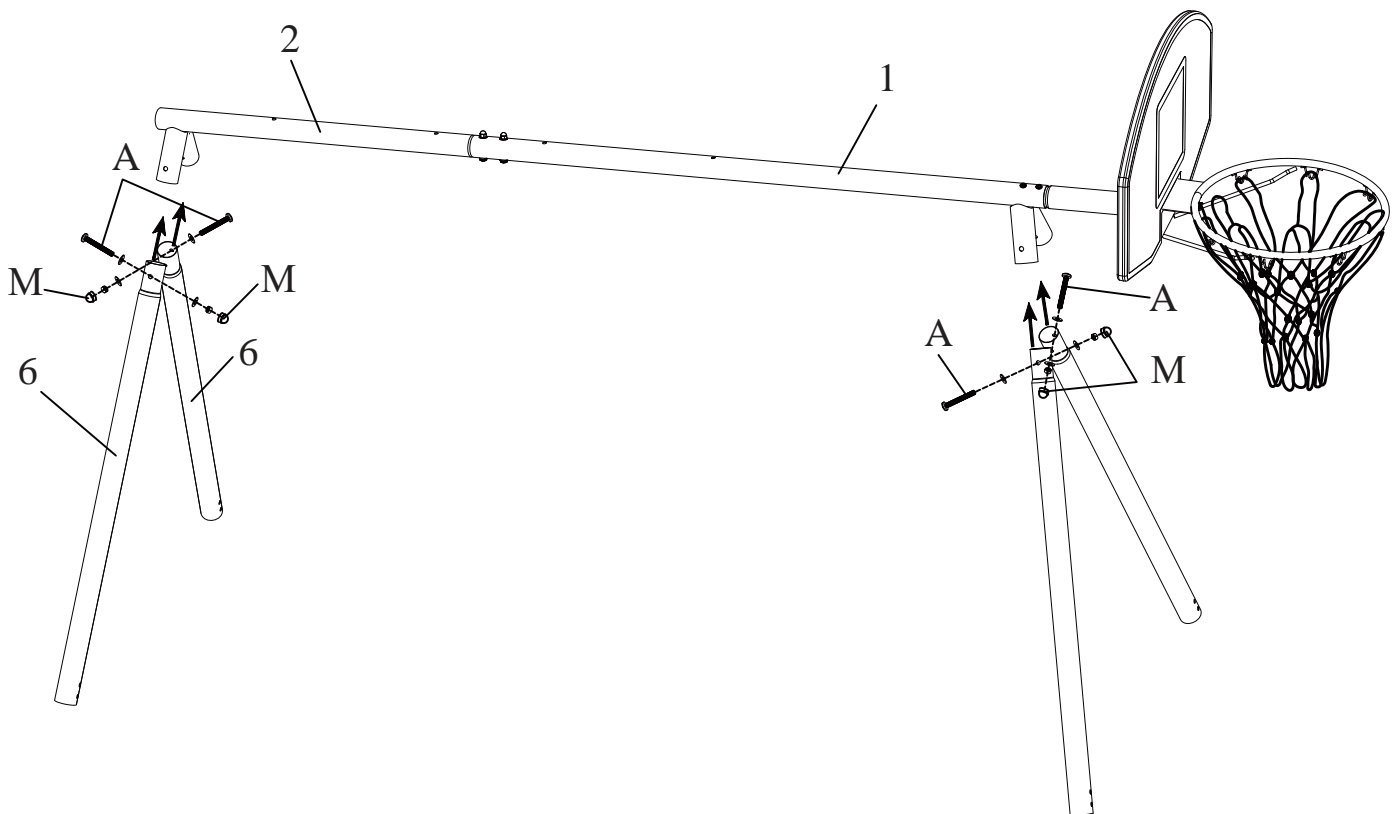

Step 6

- Insert the smaller end of the Bottom Section Leg (#7) into the Top Section Leg (#6), align the holes and secure with two sets of M8*63 Bolt, Washer (#A) and Plastic Caps (#M).
- Repeat the same step to attach the remaining three Bottom Section Legs (#7).

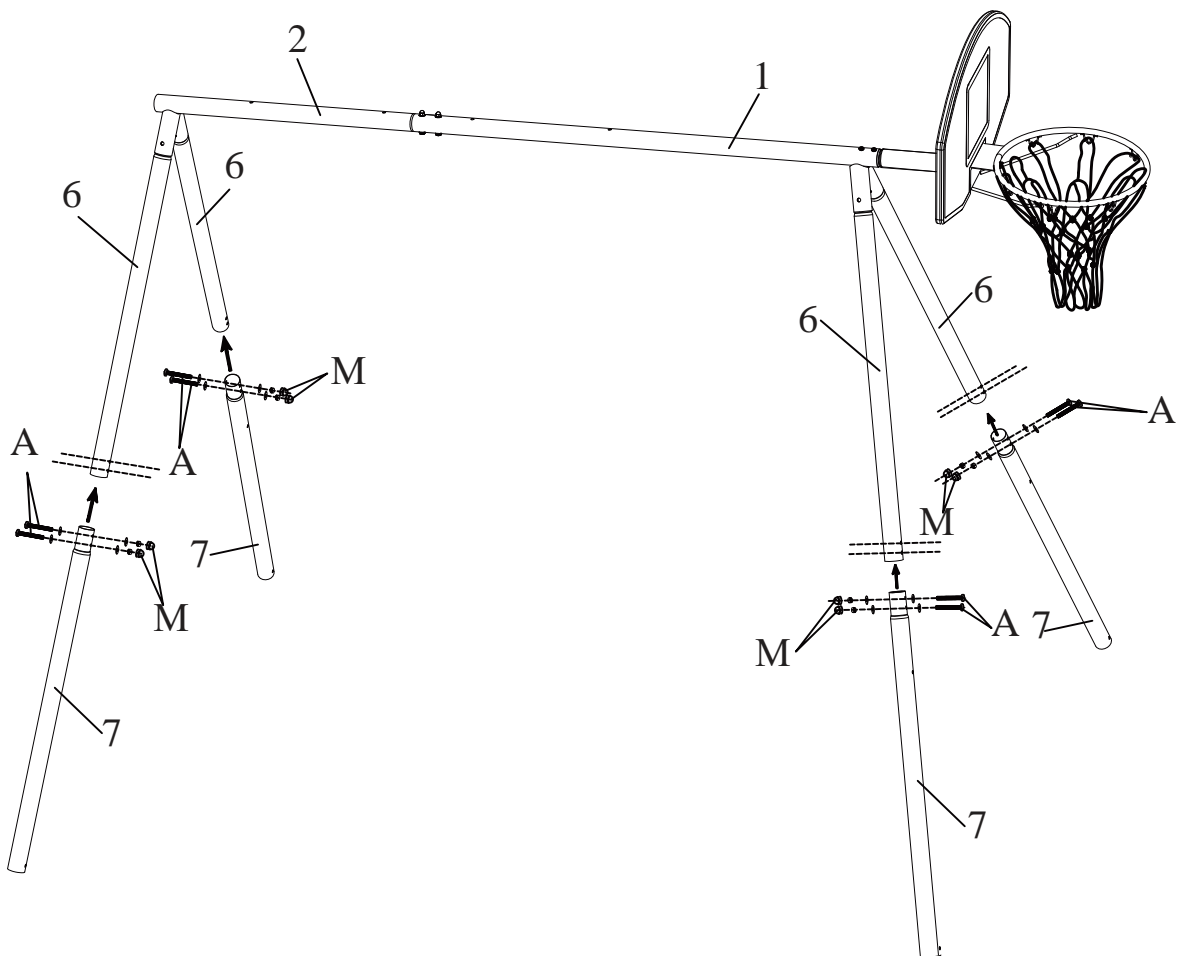

Step 7

- Attach the Cross Bar (two holes) (#4) to Bottom Section Leg (#7), and secure with M8*63 Bolt, Washer (#A) and Plastic Caps (#M).
- Repeat the same step to assemble the other Cross Bar (#5).
- The two holes on Cross Bar (#4) will be used for slide installation later, which should be installed on the side without basketball set.

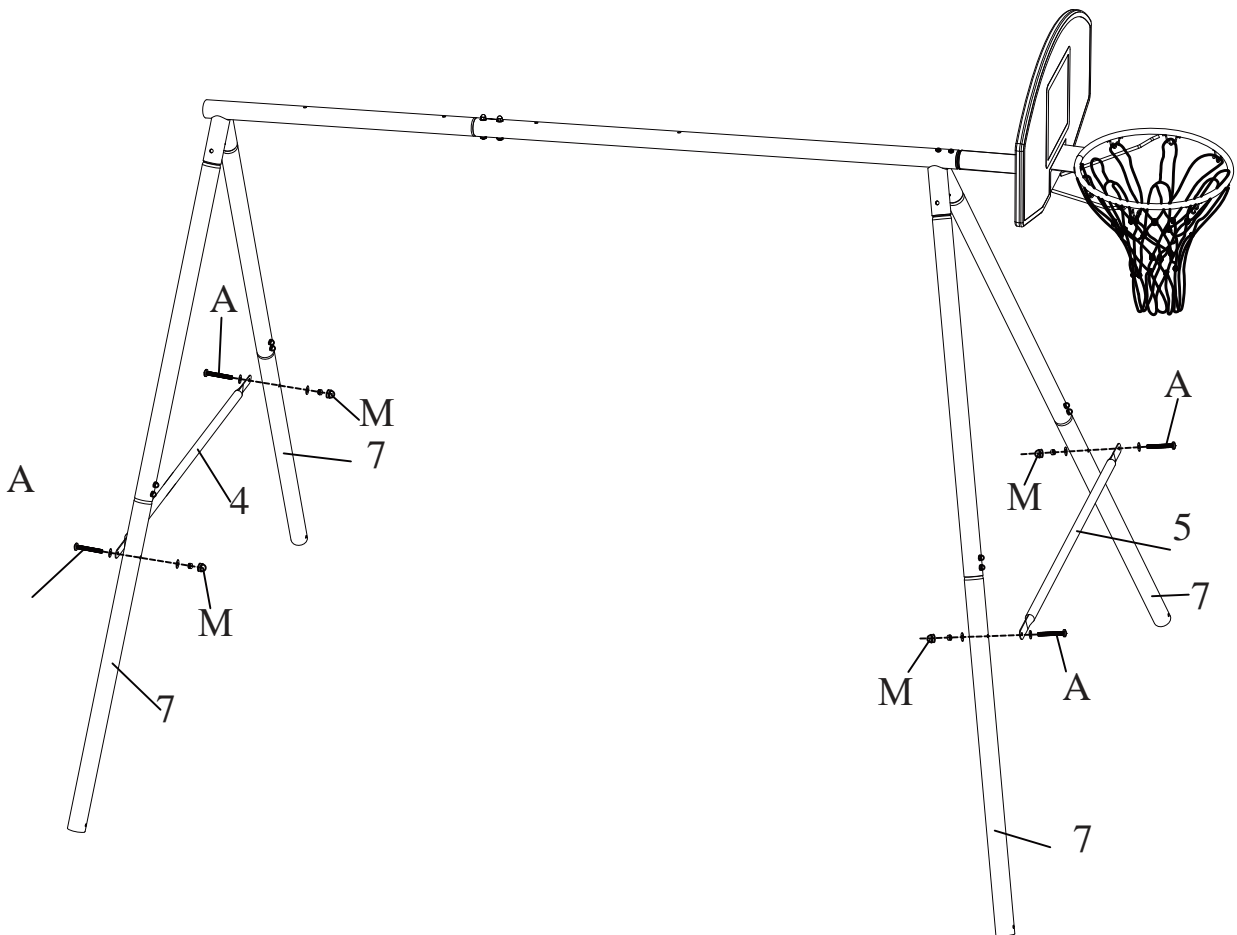

Step 8

- Insert one end of the Chains (#20) into the holes on Left Top Bar (#2), and secure with two sets of Washer (#O), Nut (#N) and Plastic Cap (#M).
- The Swing Seat (#21) and Chains (#20) are PRE-ASSEMBLED. If you find this part loose, attach the Seat (#21) to the Chains (#20), and secure with Washer (#O), Nut (#N) and Plastic Cap (#M).

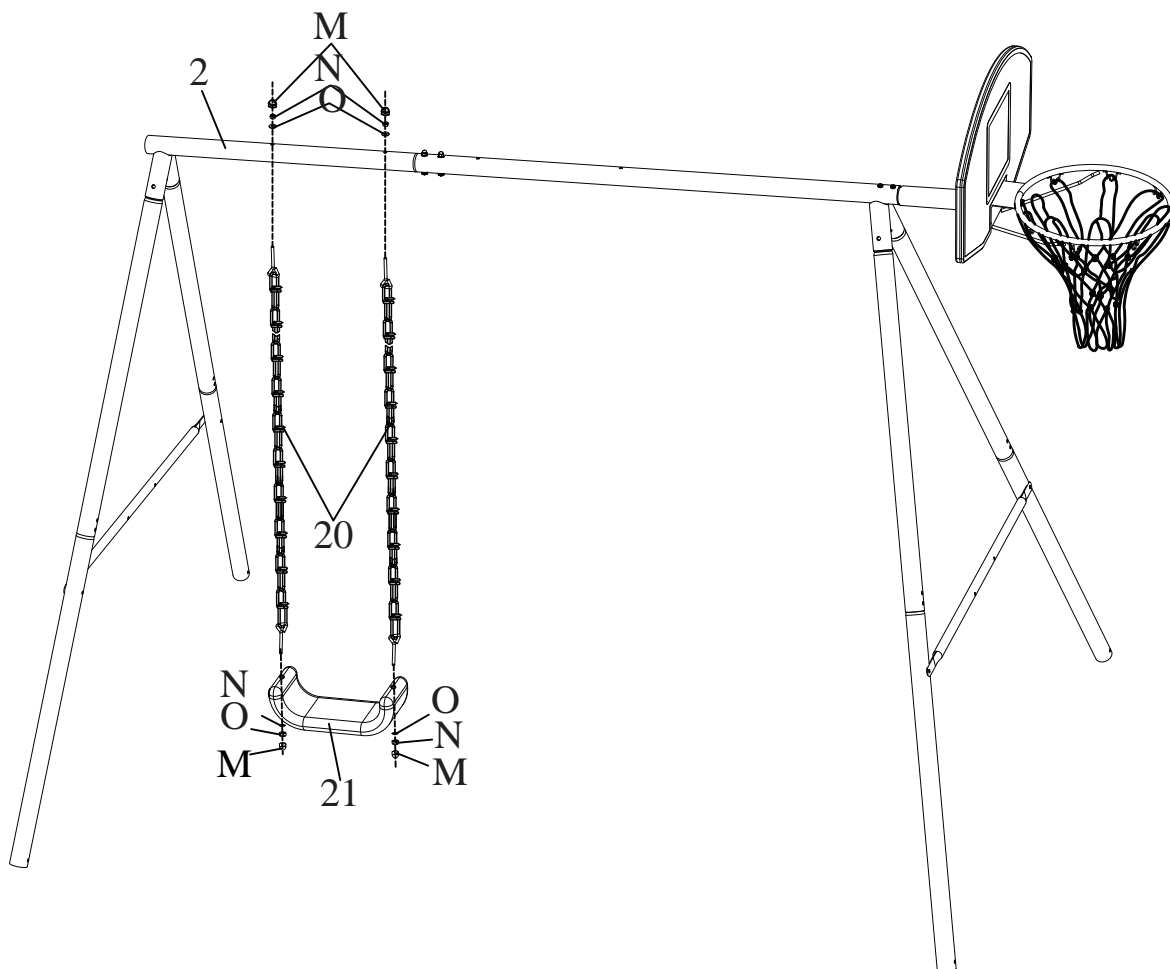

Step 9

Insert Horizontal Bar (#12) into the holes on Long Top Bar (#1), secure Washer (#O), Nut (#N) and Plastic Cap (#M).

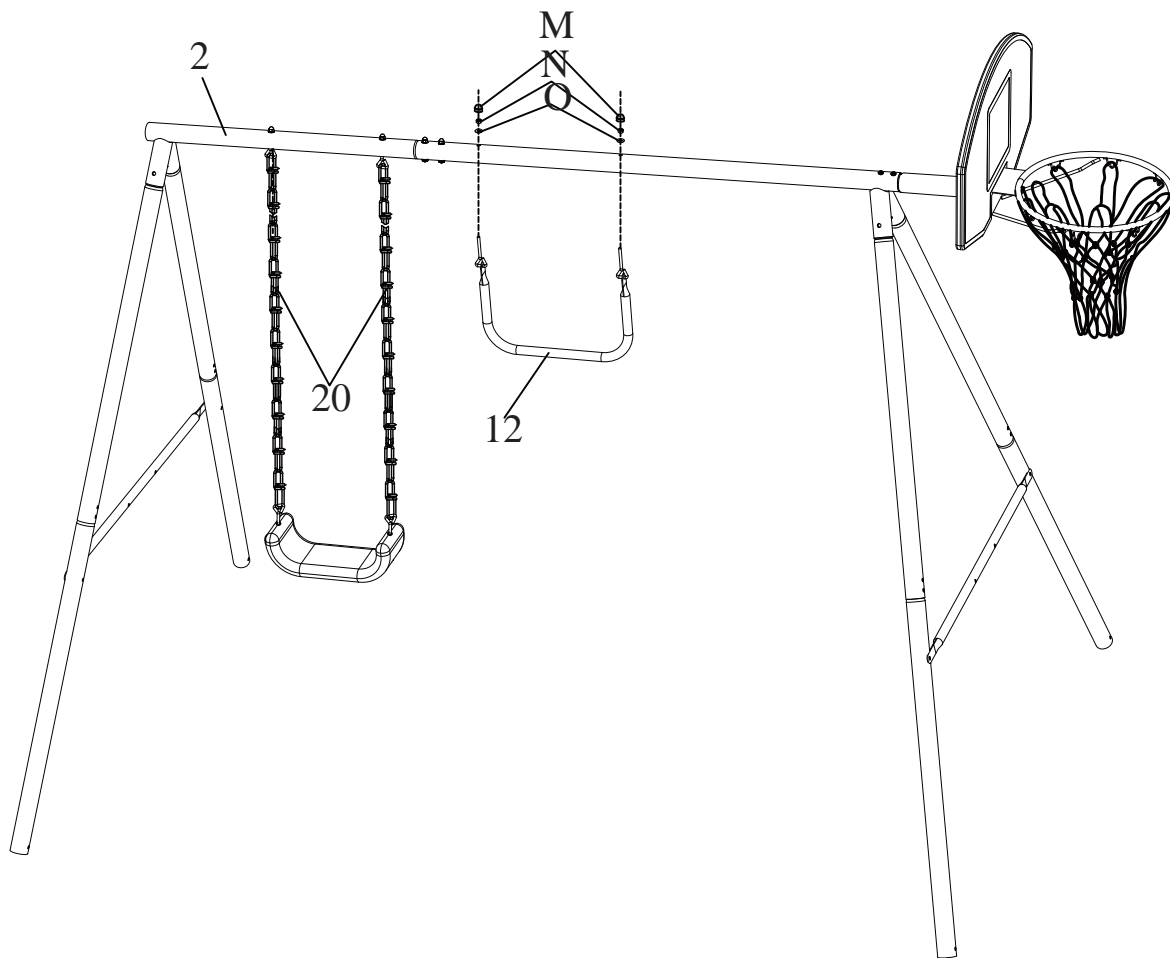

Step 10

- Attach Bracket Clamp (#10) and Bracket (#11) to Long Top Bar (#1) as shown.
- Secure with two M8*25 Bolts, Washers (#B) by using special socket wrench.

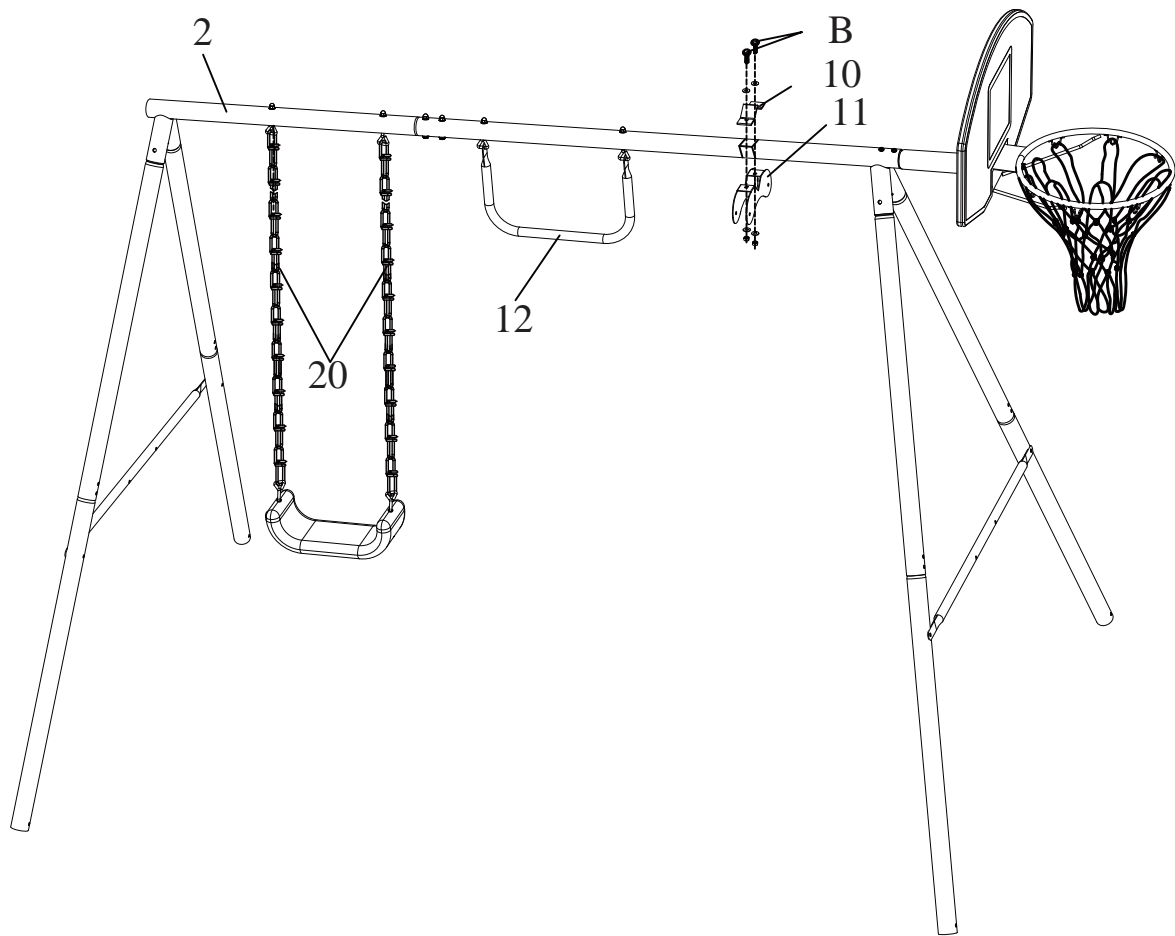

Step 11

- Attach Footrests (#26) to Section Hangers (#8), secure with M5*20 Bolt, Washer (#H).
- The white plastic top of Section Hanger (#8) is PRE-ASSEMBLED. Please tighten it before continuing next step.
- Attach Section Hangers (#8) to the Bracket (#10), and secure with M6*45 Bolt, Washer (#C).

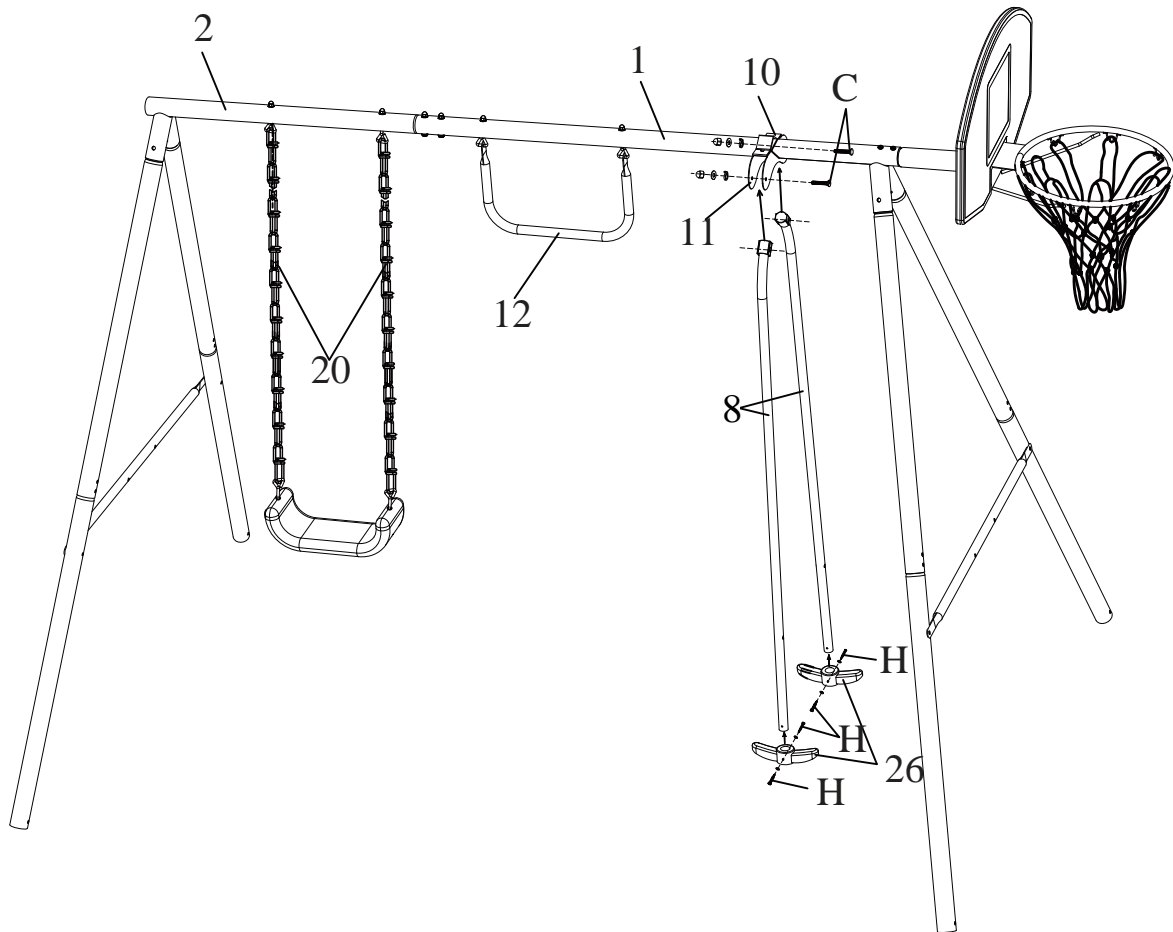

Step 12

- Insert Large Nylon Bearing (#27) into the holes on Section Hanger (#8), then attach the Glide Seat Support (#9) next to the Bearing (#27).
- Insert J-Bolt (#G) through Glide Seat Support (#9), Nylon Bearing (#27), Section Hanger (#8), and slightly tighten it.
- Repeat the same step for the other side. Tighten all bolts when all parts are in place.

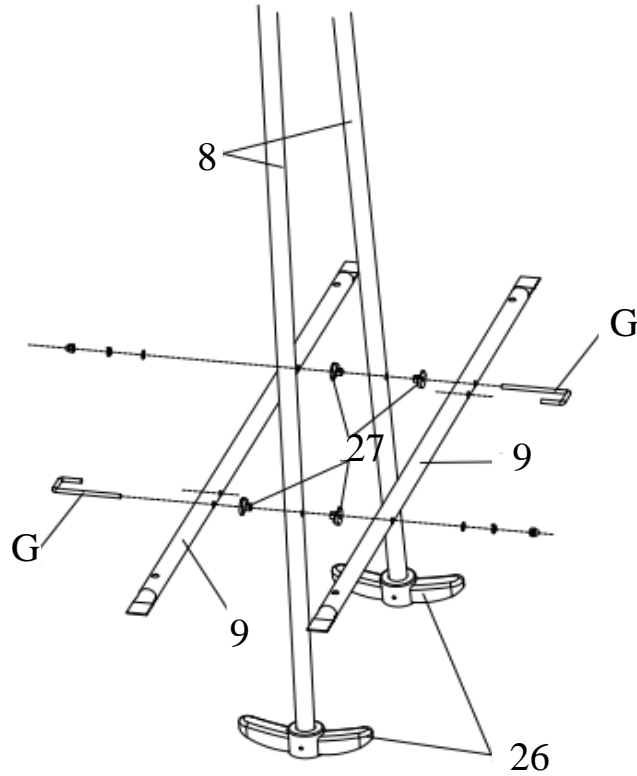

Step 13

Attach Glide Seat (#22) to Glide Seat Support (#9), secure with M6*35 Bolt, Washer (#F).

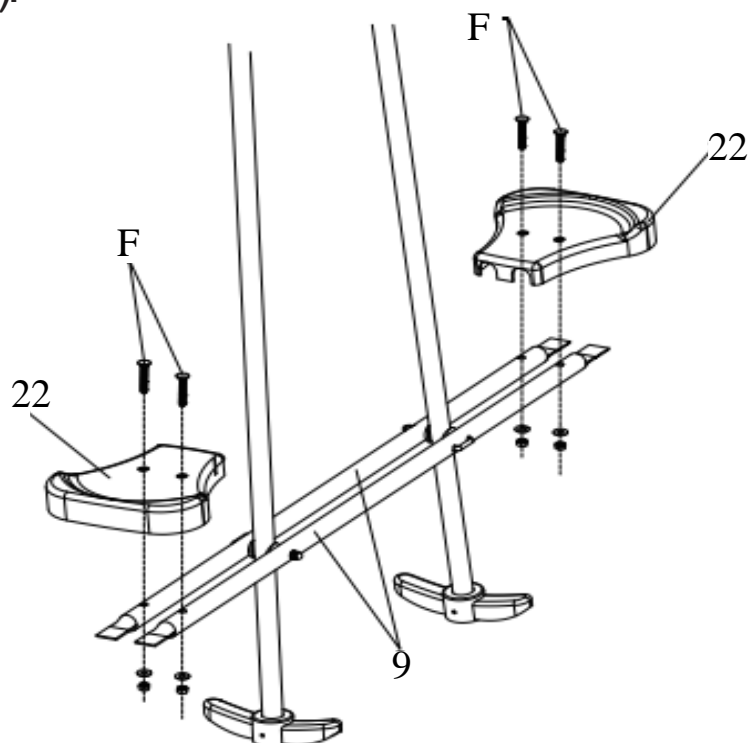

Step 14

- Attach Slide Ladder Steps (#18) to Slide Support (#16), and secure with four sets of M6*35 Bolt, Washer (#J).
- Attach Slide Leg Tube (#17) into Slide Support (#16), secure the lower hole with two sets of M6*35 Bolt, Washer (#J).
- Make sure the holes are aligned before completely tightening the bolts.

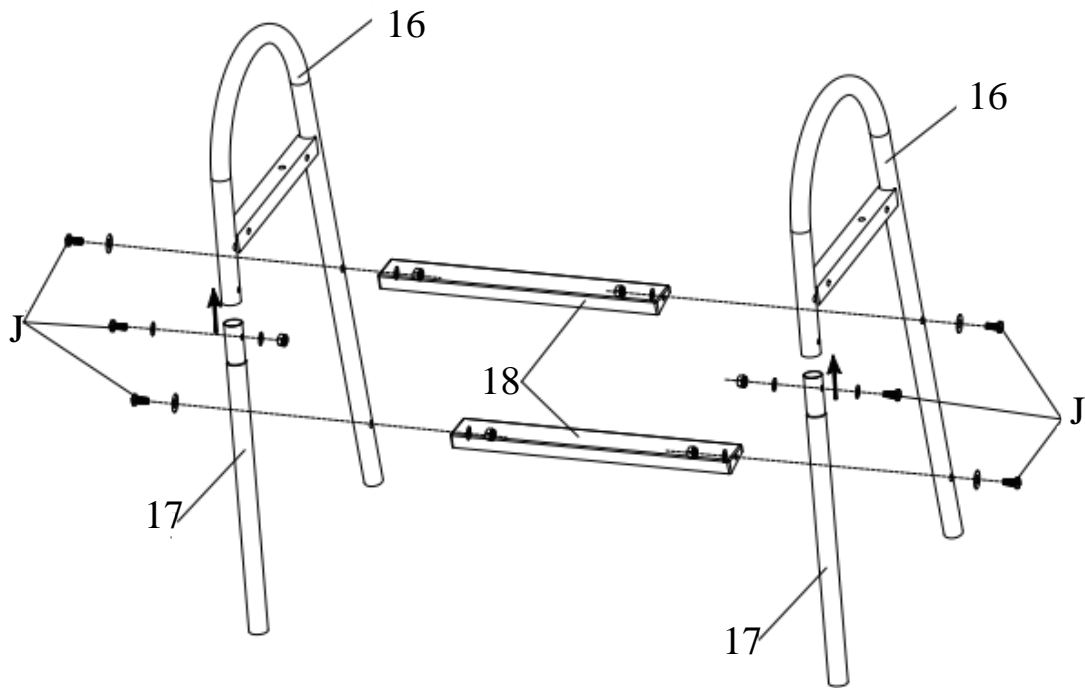

Step 15

Insert the ends of Slide Top Support Bar (#19) into Slide Support (#16), and secure with M6*60 Bolt, Washer (#L).

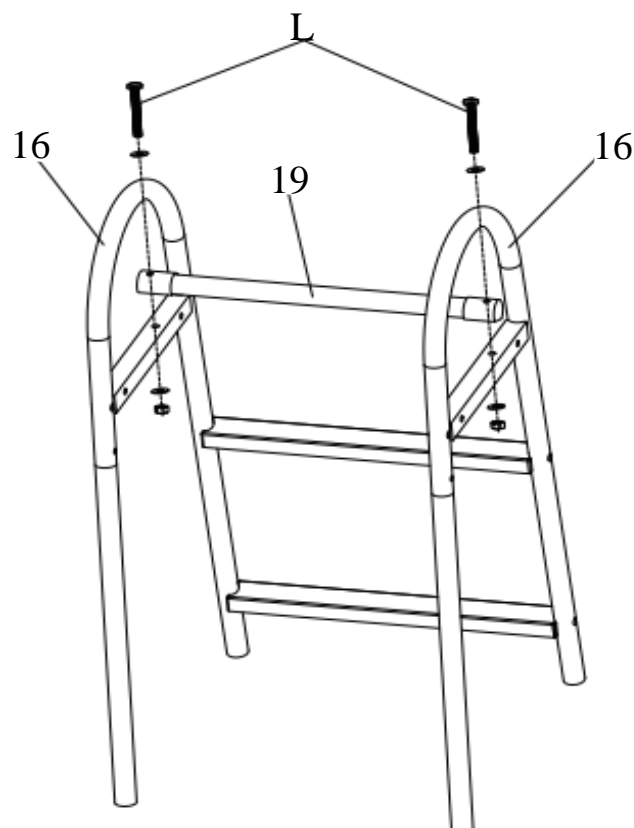

Step 16

- Attach the Slide (#23) to the Slide Top Support Bar (#19)
- Insert M6*90 Bolt, Washer (#I) through the upper hole on Slide Support (#16), Slide (23) and tighten them.

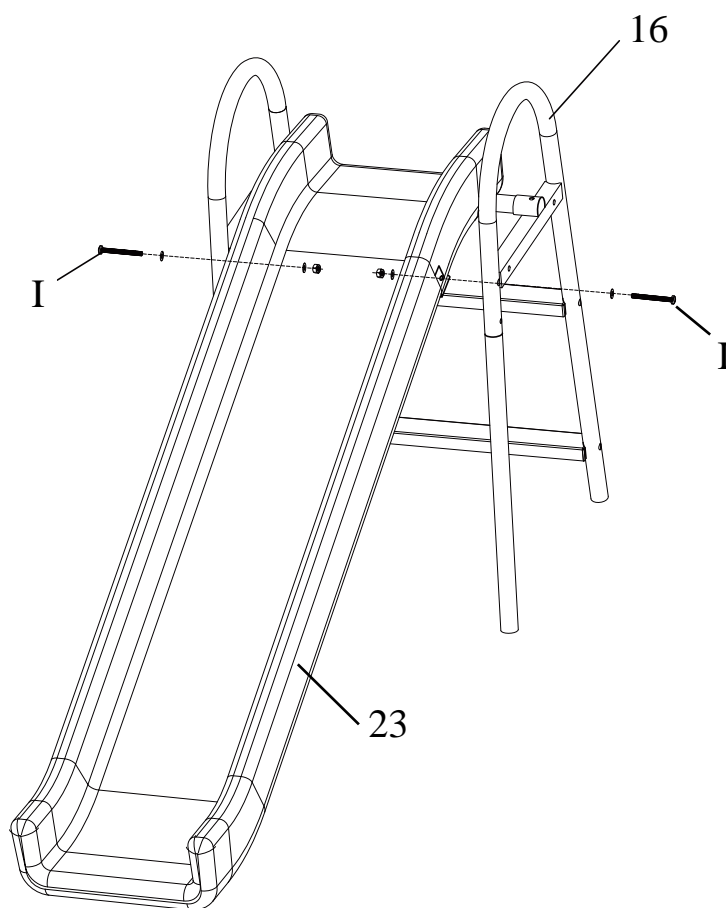
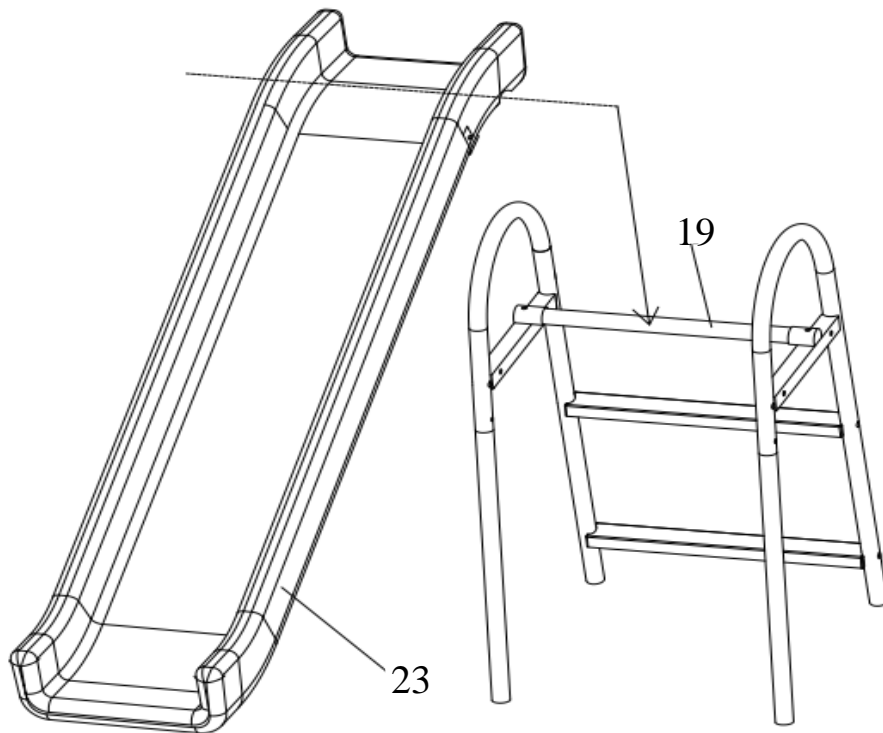

Step 17

Attach Plastic Connector (#24) between Slide Support (#16) and Cross Bar (Two Holes) (#4), secure with M6*100 Bolt, Washer (#K).

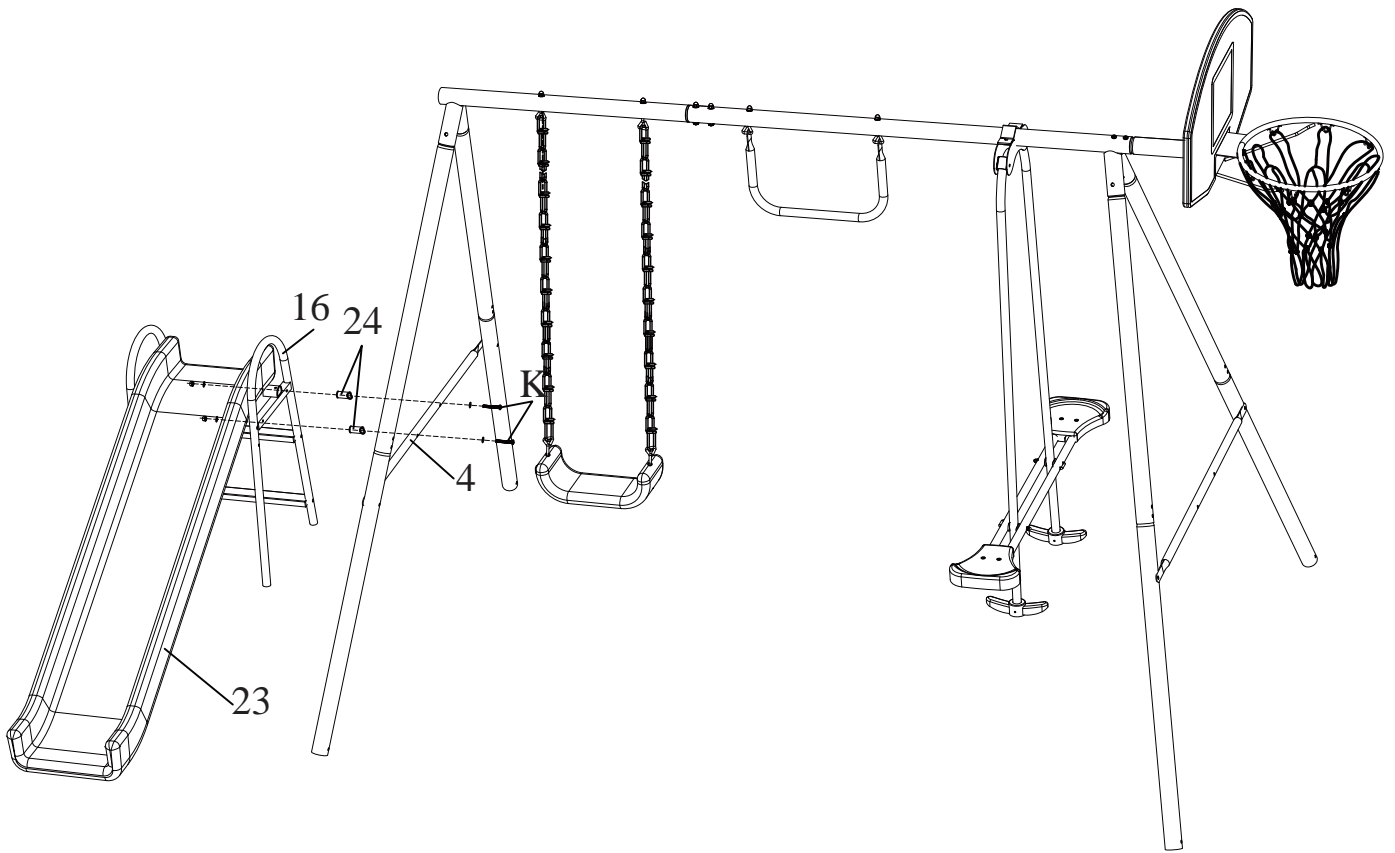

You have finished assembling your playground equipment.

Now go back and securely tighten all bolts and nuts before using the playground equipment.

- ❖ NOTE: Make sure to go back to check all hardware and securely tighten all bolts and nuts before using the playground equipment.
- ❖ ! WARNING: Do not let children use the playground equipment until it is properly assembled and anchored.
- ❖ By anchoring your set with Ground Anchors, you will be able to move your gym set at a future date. Either method is suitable for hard soil (clay, etc.) If your soil is soft (sand, etc.), the corkscrew method is recommended. If you wish to permanently secure your gym set, either type of anchor may be set in concrete. Ensure equipment is firmly anchored (cementing is usually recommended). When equipment is cemented; do not bury the legs more than three inches below the ground surface. This will ensure sufficient space remains under the swinging plays. Be certain that all anchoring devices (including concrete) are placed below the level of the playing surface or below ground level to prevent tripping.
- ❖ Corkscrew Anchors is not included
- ❖ Be sure the swing set is located on level ground
- ❖ Turn the corkscrew anchor into the ground until only the hook end is above the ground next to the leg.
- ❖ Insert the hooked end into the bottom opening of the leg.
- ❖ Ensure that the hooked end is secure in the leg opening.

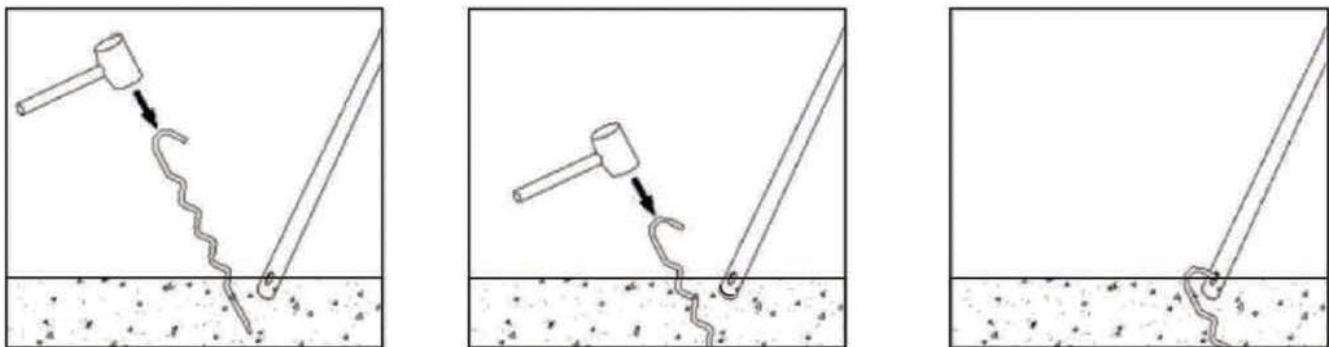

NOTE: ANCHORING

- ❖ If the swing set is set up on grounds with sandy soil condition, it must be anchored with concrete footing (concrete not included)
- ❖ Be sure the swing set is located in level ground
- ❖ Dig holes around swing leg tube as shown below in drawing. As you dig down

and create a cylindrical hole, you should use shovel to carve out the lower part of the hole, to create a large diameter hole bottom

- ✧ Place 2 inches brick or gravel bed as shown in drawing below
- ✧ Use about 45 lb of concrete per leg
- ✧ Cover concrete with dirt and protective surface material

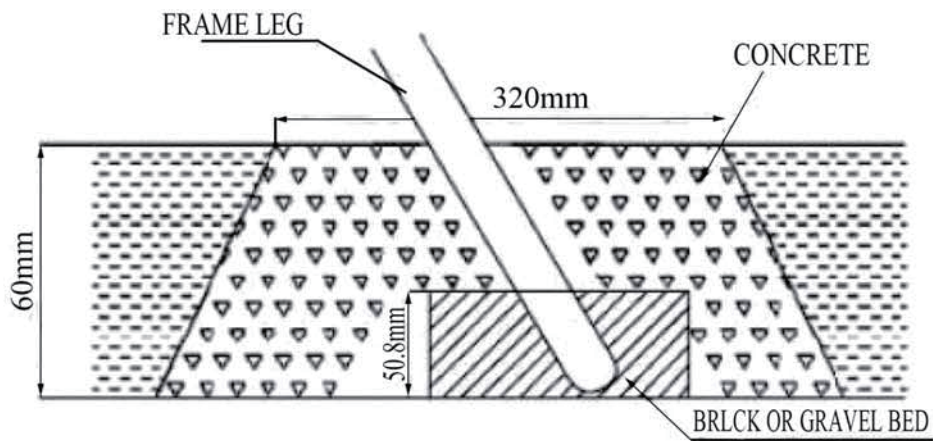

NOTICE

- Please read all instructions before attempting to install or assemble this item. Assembly should be done by adults only.
- Firmly secure all screws before use.
- Reconfirm that all bolts, screws, and knobs are secure every 90 days.
- Product is intended for outdoor use.
- If any parts are missing, broken, damaged, or worn, stop using this item until repairs are made and/or factory replacement parts are installed.
- Do not use this item in a way inconsistent with the manufacturer's instructions as this could void the product warranty.

CAUTION DURING USE

- Do not hang from the rim or climb on the pole. Do not climb on the base or structure in general, as this could result in serious injuries.
- Adjustment and moving of the basketball set must be carried out by adults.
- Always check the unit to ensure the base is full of water or sand, and that all fittings and hardware are tight before each use.
- Always place the base of the set on a flat surface.
- Do not allow water to freeze in the base.
- The set requires two people for assembly.
- Check the base regularly for any leakage before playing.

