

ASSEMBLY INSTRUCTIONS

ITEM NO.WF280661

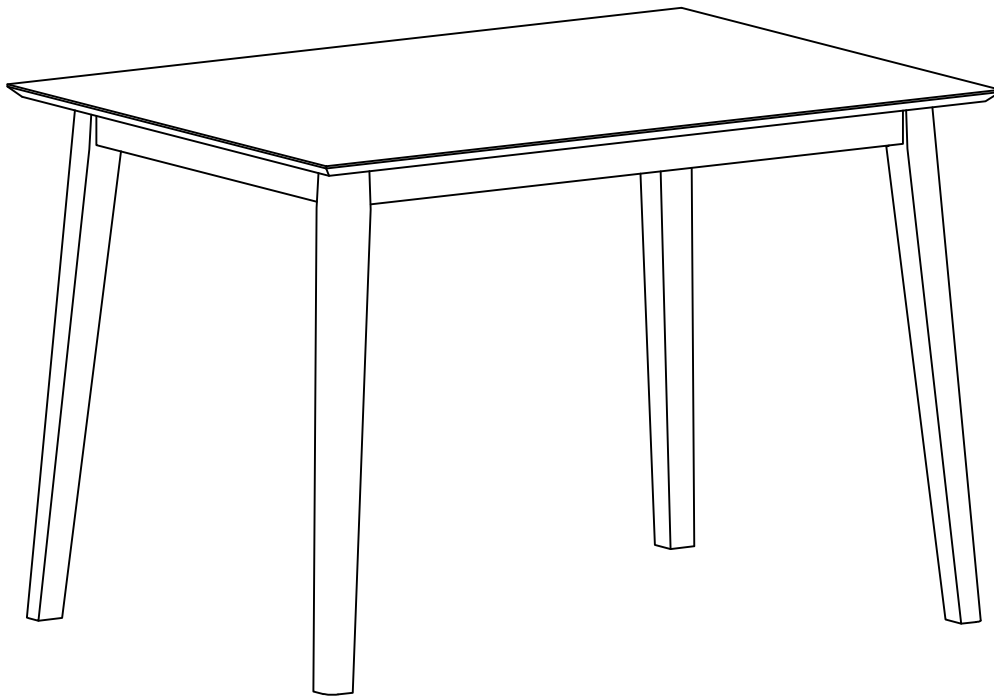



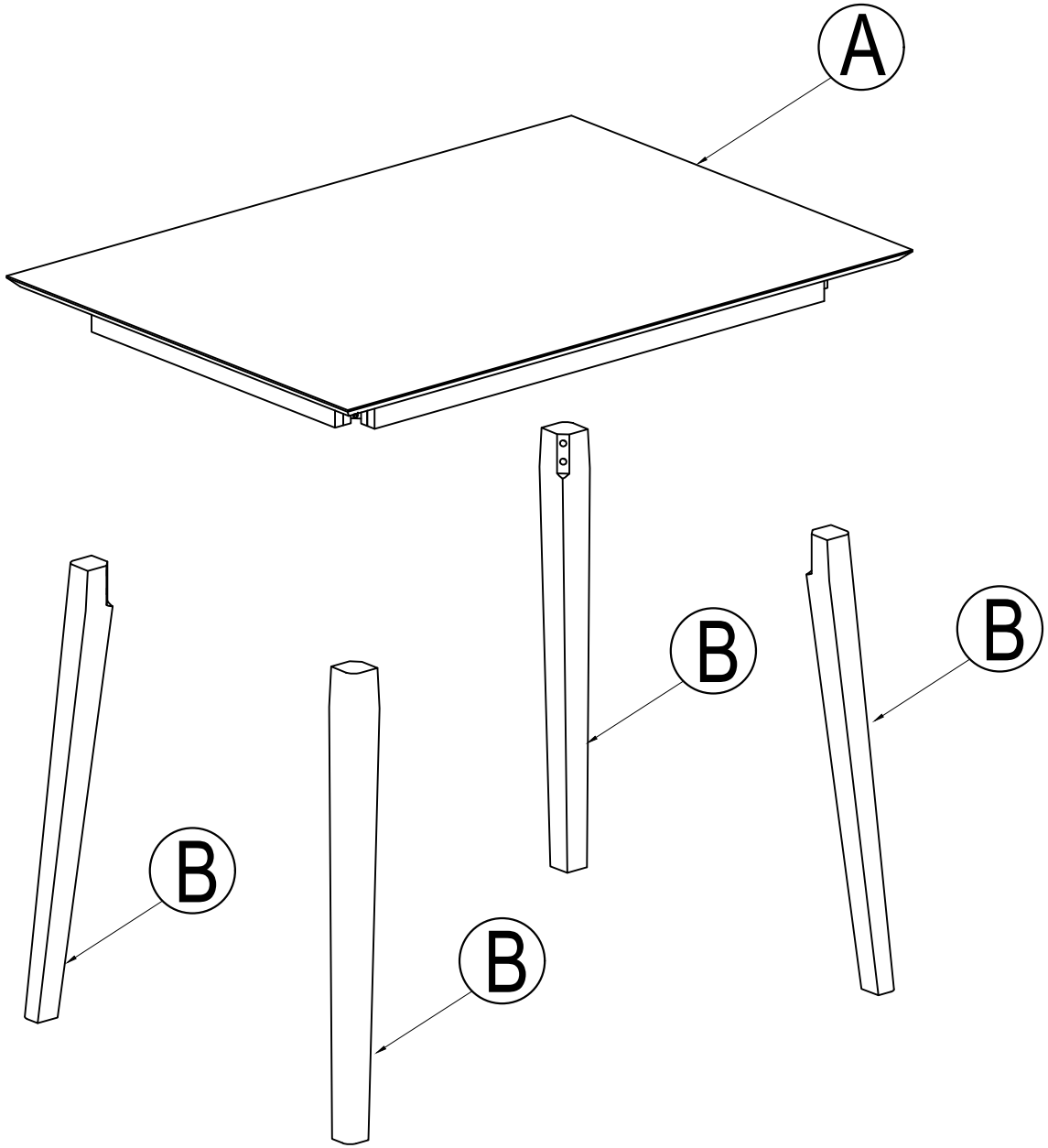

IMPORTANT NOTE :

- ① PLACE ALL PARTS ON A CLEAN AND SMOOTH SURFACE SUCH AS A RUG OR CARPET TO AVOID THE PARTS FROM BEING SCRATCHED.
- ② BEFORE YOU BEGIN,KINDLY FOLLOW THE ASSEMBLY INSTRUCTIONS STEP BY STEP.
- ③ DO NOT TIGHTEN ALL SCREWS AND BOLTS UNTIL THE CHAIR IS FULLY SET-UP.

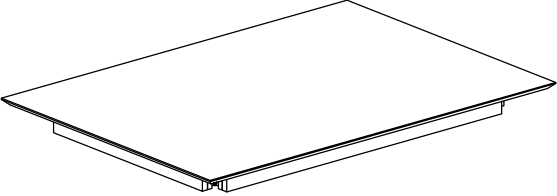
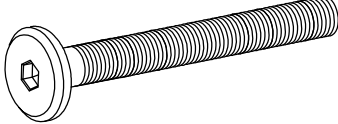
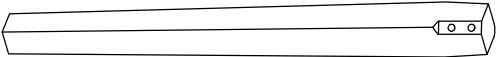

Part List

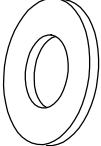
Hardware List

<p>Ⓐ</p> 	<p>①</p>  <p>Ø 5/16" x 70 mm</p>
<p>TABLE TOP (1 pc)</p>	<p>BOLT (8 pcs)</p>
<p>Ⓑ</p> 	<p>②</p>  <p>Ø5/16" x 13 mm</p>
<p>TABLE LEG (4 pcs)</p>	<p>FLAT WASHER (8 pcs)</p>
	<p>③</p>  <p>Ø5/16" x 19 mm</p>
	<p>LOCK WASHER (8 pcs)</p>
	<p>④</p>  <p>4 mm</p>
	<p>ALLEN KEY (1 pc)</p>

STEP 1:

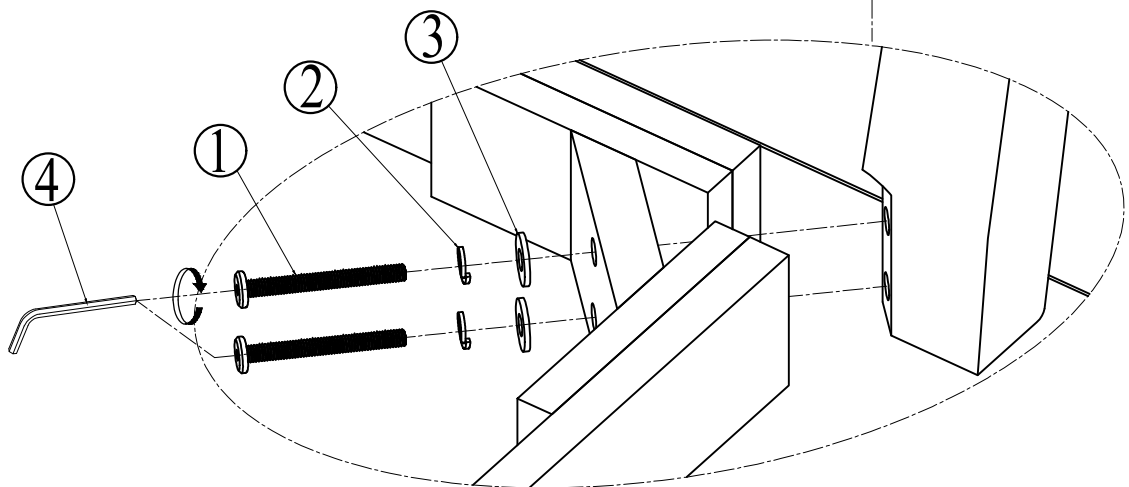
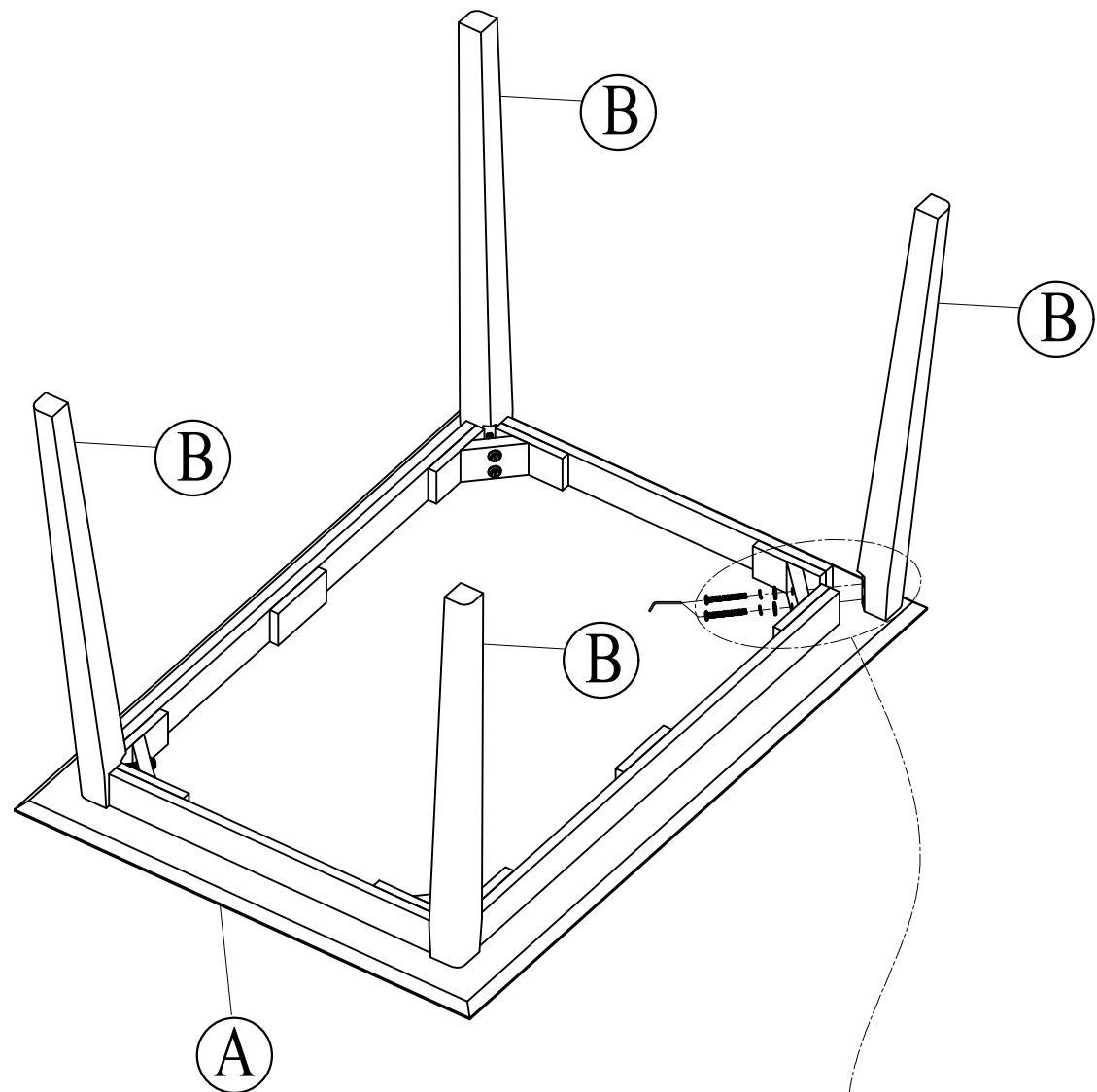

X4