

# ELECTRIC TREADMILL USER'S MANUAL



**⚠ CAUTION**

**READ THIS MANUAL CAREFULLY BEFORE USING THIS TREADMILL.**



# CONTENTS

I. IMPORTANT PRECAUTIONS -----	1
II. MAIN TECHNICAL FEATURES-----	4
III. ASSEMBLY -----	5
IV. WORKOUT GUIDELINES -----	7
V. TREADMILL OPERATION -----	8
VI. MAINTENANCE -----	13
VII. RECYCLING INFORMATI -----	15
VIII. COMMON ERRORS -----	15
IX. WARRANTY -----	17



## I.IMPORTANT PRECAUTIONS



 MINIMUM USER HEIGHT	140 cm	 Kg	MAX USER WEIGHT	100 kg.
---	--------	--	-----------------------	---------



THE SECURITY KEY HAS A MAGNET WHICH MUST BE PUT IN THE DISPLAY. AT THE END OF THE LACE THERE IS A CLAMP WHICH SHOULD BE ATTACHED TO THE CLOTHES.THE TREADMILL WILL START WORKING ONLY IF THE KEY IS PLACED IN THE DISPLAY.THIS IS ESSENTIAL.

A CORRECT LUBRICATION OF THE TREADMILL WITH SILICON OIL OR TEFLON IS REALLY IMPORTANT. THIS LUBRICATION MUST BE PERFORMED REGULARLY DEPENDING ON EACH PERSON, EVEN BEFORE ITS FIRST USE.

### WARNING:

YOU MUST PRESERVE THE ORIGINAL PACKAGING WITH ITS PROTECTIONS, PURCHASE RECEIPT, MANUAL AND COMPONENTS DURING THE GUARANTEE PERIOD.

In order to decrease the risk of suffering severe injuries, read carefully all the important instructions and warnings regarding the use of a treadmill before using it.

**Our company** doesn't take any responsibility for personal injuries or property damages resulting from the use of this product.

1-Before starting any workout program, consult your doctor. It's specially important for people older than 35 years old, people with health problem and pregnant women.

2-The owner must ensure that all users are correctly informed about the warnings.

3-Use the equipment as explained in the instructions manual.

**4-Keep the equipment in an enclosed area, away from dust or humidity. Don't store it in a garage, indoor backyard or near the water. Humidity, dust and water could lead to a malfunction of the equipment, annulling its guarantee.**

5-Place the unit on a flat surface. If the surface is uneven, the proper functioning could be affected. Some models include levelers or leveling threads on the back of the legs to aid in leveling. Please read the manual to verify if your unit is provided with one of them.

6-The unit must be placed in a ventilated area. Don't use it in places with sprays or with oxygen dispenser. The air you breath may be affected and cause an accident.

7-Keep children younger than 12 years old and pets away from the equipment. Keep the security distance.

**8-Check in the manual the maximum weight your equipment can support. An excessive weight could lead to a malfunction in the operating system, which won't be covered by the guarantee.**

9-Wear suitable clothes and shoes. Do not use loose clothe that may get hooked.

10-If your equipment is working through a power supply: make sure that the power cord and plug are in good conditions. Carry out the connection only when the circuit has ground connection, otherwise it could cause damages on the equipment or in the property which the guarantee won't cover. Power cords must be away from hot surfaces.

11-If it is a battery-powered unit: check and make sure that they are charged enough so the display will fully function.

12-If your equipment is provided with a security key, please understand the produce before using it. The security key has a magnet which must be put in the display. At the end of the lace there is a clamp which should be attached to the clothes.The treadmill will start working only if the key is placed in the display.**THIS IS ESSENTIAL.**

13-If your unit works thanks to a power supply: don't put it into operation while you are on the belt. The motor would be unnecessarily loaded. The right way is placing yourself with open legs, each one on a side of the belt and sit up once it is ongoing.

14-If your unit works with an electric supply: check the speed it can reach, for your security. The best is to adjust gradually the speed in order to avoid sudden changes.

**15-If your unit works through an electric supply: never leave the machine unattended while it's working. Take the security key off, turn the "on" button into "off" and unplug the power cord.**

16-If your equipment is provided with a pulse sensor, you may know it isn't a medical instrument. It's designed as a help for the workout and determines the tendencies of heart rates. There are some factors which could affect the accuracy of the heart rate interpretations, for example the movements of the user.

17-The machines don't take too much space as they can be folded. Once folded, make sure that all is well assembled to the locking system, either if it has a lock or an hydraulic engine. Don't try to move it or raise unless you are insured. Should any damage happen being the machine uninsured, it won't be covered by the guarantee.

**18-Check and tighten all screws on a regular basis, because due to vibrations screws and nuts tend to loosen. Damages caused by a lack of maintenance won't be covered by the**

**guarantee.**

**9-A correct lubrication of the treadmill with silicon oil or Teflon is REALLY IMPORTANT.**

This lubrication must be performed regularly depending on each person, even before its first use. The lubrication must be carried out this way: disconnect the equipment of the electricity supply (in case you have one), pull up the tapestry from the side with one hand and spread the oil on the board. Please repeat this procedure from the other lateral side. Connect the equipment to the power supply (in case you have one) and turn the "on" button (red button) into the correct position (I), insert the security key and let the treadmill work for several minutes without any weight on it. Repeat this action on a regular basis.

**20-Two people will be needed in order to take the unit from the package. Otherwise, the damages caused in this moment won't be covered by the guarantee.**

21-Don't let any object fall into the grooves.

22-If the unit works through a power cord: unplug always the power cord before cleaning it, after the workout and before performing any maintenance duty.

23-This unit is designed for a domestic purpose and in an interior place, not for business environment or outside.

24-Do a workout with stretches before and after the sessions, you will avoid injuries.

25-Drink water before, during and after the workout.

26-If you start feeling pain or dizziness while training: **STOP IMMEDIATELY.**

**27-YOU MUST PRESERVE THE ORIGINAL PACKAGING WITH ITS PROTECTIONS, MANUAL AND COMPONENTS DURING THE GUARANTEE PERIOD.**

28-The accessories can be different to the other models.

29-This electronic product can't be thrown under any circumstances into the municipal rubbish bins. With the aim of preserving the environment, this product must be recycled according to the applicable law of your country. Please contact your town council to know more about this procedure.

30-Should you need technical assistance or advise with the installation of pieces, You can get in touch with us .

**YOU MUST KEEP THE PURCHASE RECEIPT IN ORDER TO HAVE ACCESS TO THIS SERVICE**

**KEEP THESE ADVISES FOR FUTURE REFERENCES**

## II.MAIN TECHNICAL FEATURES











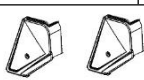



Input Voltage	220V±10%
Frequency	50/60 HZ
Running area	1230X420mm
Function	Time, Speed, distance, Calorie, heart rate, MP3 input,Bluetooth App
Speed Range	1.0-14 KM/H
Incline	0-5% manual incline
Max user weight	100kgs
Power	2.0HP

### III.ASSEMBLY



**NOTICE:ASSEMBLY REQUIRES TWO PERSONS**

Main part	Name		Q'ty		
	1. Main frame		1set		
	2. Stand Tube Cover		1pair		
	3. Spring absorption plastic cover		1pair		
 1.Main frame		 2.Stand Tube Cover			
No.	Fittings	Qty	No.	Fittings	Qty
①	 M8*20	6	⑦	 6mm Wrench	1
②	 M8*45	2	⑧	 Multi Wrench	1
③	 ST4*15	2	⑨	 Silicone oil	1
④	 M8 Nut	2	⑩	 User's Manual	1
⑤	 Flat washer	8	⑪	 MP3 Wire	1
⑥	 5mm Wrench	1	⑫	 Security Key	1

### STEP 1

1. Carry out the machine from the package by two persons and place it lightly on flat floor, and put other fittings beside the machine. Lift up the stand tube and electronic watch according to the picture(make sure not to press the signal wire)
2. One person hold the electronic watch steady and the other person puts **4PCS M8\*20** and **2PCS M8X45** screw and fix them onto the stand tube with **FLAT WASHERS**.

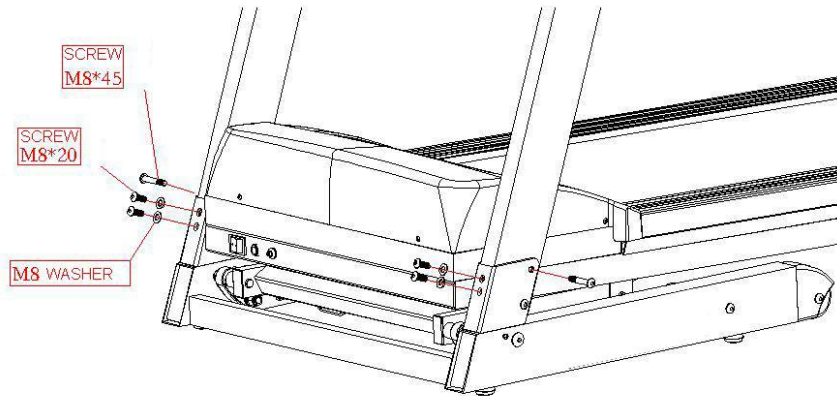
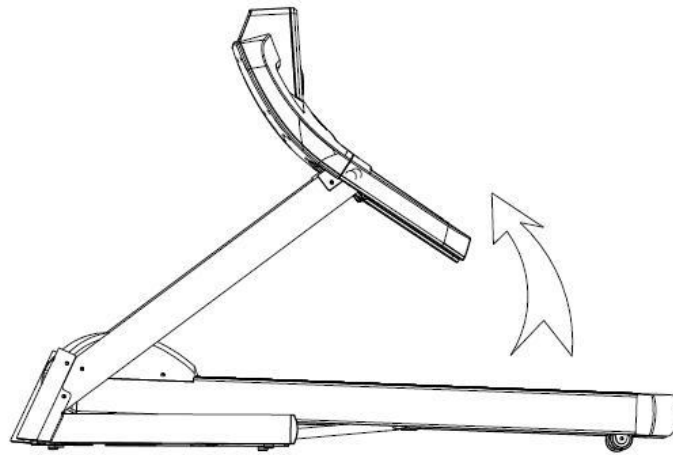

## STEP 2

Use 2PCS M8\*20 screws and FLAT WASHERS to screw up the left and right stand tube with the electronic watch.

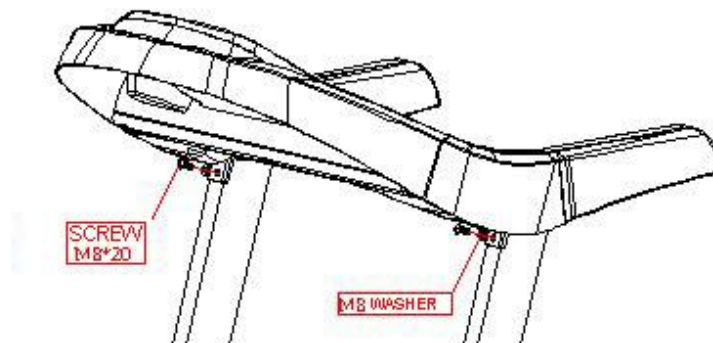



## STEP 3

Use 2PCS ST4X15 screws to fasten the plastic cover at bottom of stand tube.

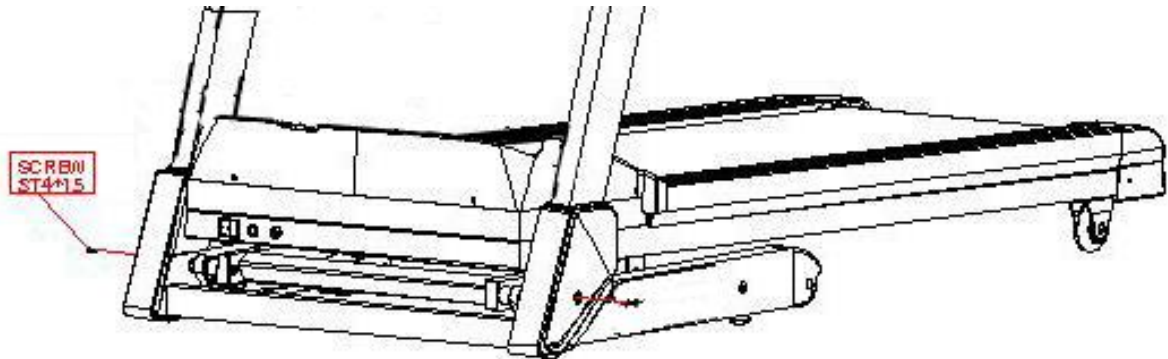

## IV.WORKOUT GUIDELINES

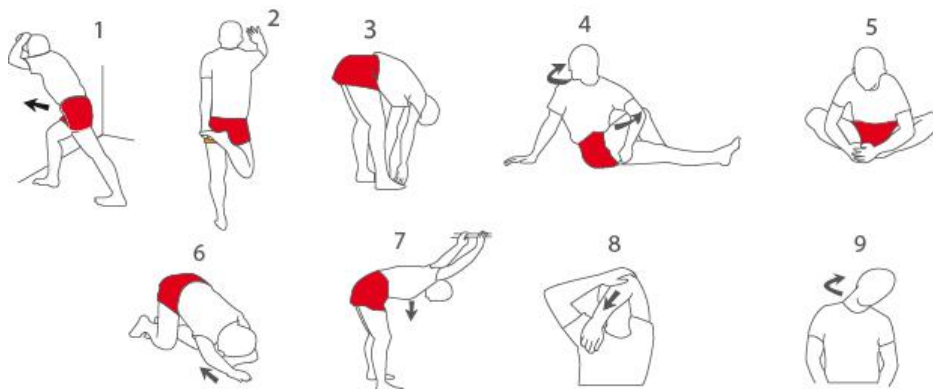

**BEWARE:** Before starting to use this or any exercise programs, consult your doctor. This is specially important for people older than 35 years old, or for people with health problems.

If your equipment is provided with a pulse sensor, you must keep in mind this isn't a medical instrument. Several factors can vary the accuracy of the heart rate interpretations. The pulse sensor is just a help for the work outs, determining the general tendency of the heart rate.

### **PROGRAMM WITH WARM UP WORKOUTS:**

**WARM UP:** Start stretching and slightly activating the muscles between 5 and 10 minutes. The warm up will increase your corporal temperature, your heart rate and your blood flow, making you ready for the workouts.

- **WORKOUT FOCUSED ON THE TRAINING AREA:** Do some exercises during 20-30 minutes with your heart rate (don't maintain your heart rate more than 20 minutes during the first weeks of the exercise program). Breath constantly and

deeply during the workout (never hold your breath).

- **COOL DOWN:** Finish with stretching exercises during 5-10 minutes. Stretching increases the flexibility of your muscles and help you to avoid injuries after the workouts.

**FREQUENCY OF THE WORKOUT:** In order to be fit or improve your shape, complete three workout sessions each week, with a rest day between the workouts. After some months of regular training, you will be able of completing up to five workouts a week.

## V.TREADMILL OPERATION

### HOW TO FOLD AND MOVE THE TREADMILL



# COMPUTER

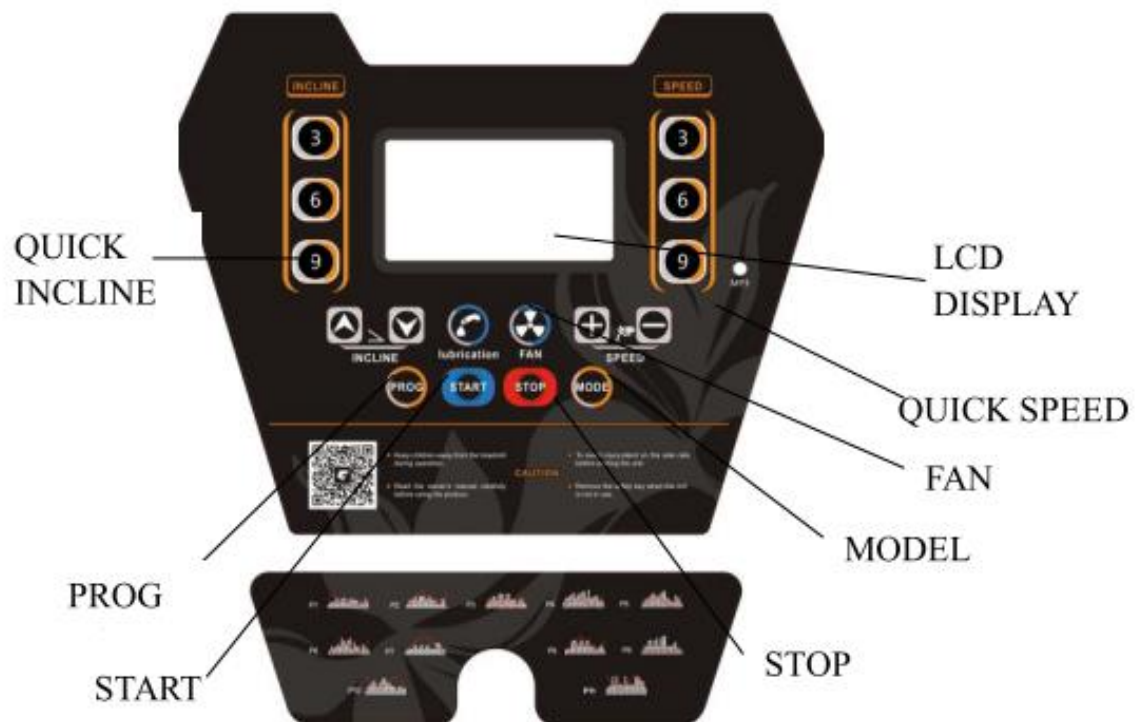

# MANUAL

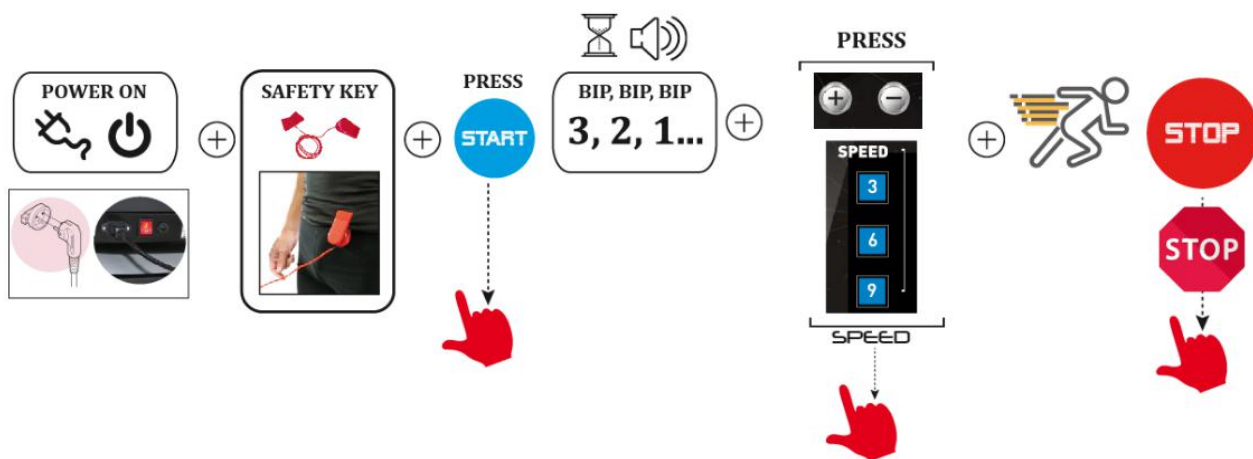

# MODE

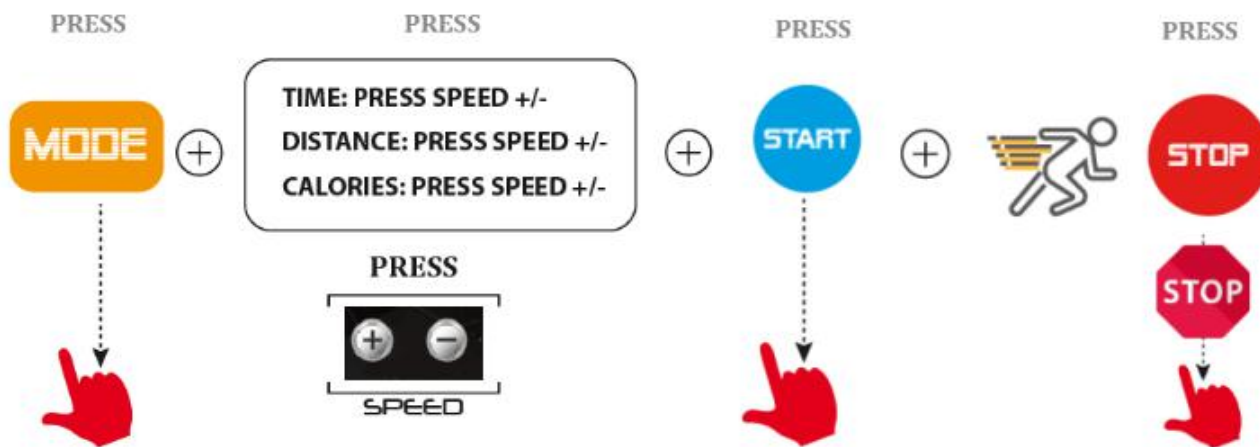

# PROGRAM

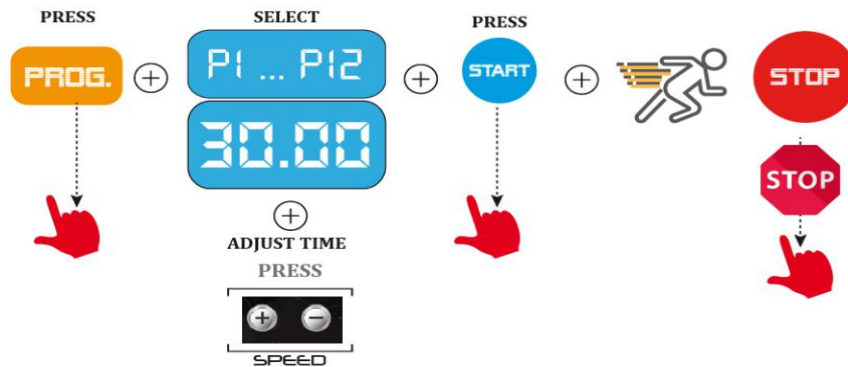

TIME		Setting time / 20= operation time of each section																			
		1	2	3	4	5	6	7	8	9	10	11	12	13	14	15	16	17	18	19	20
P01	SP	2	3	5	5	5	5	5	5	5	5	5	5	5	5	5	5	5	3	2	
	IN	2	3	4	4	4	4	4	4	4	4	4	4	4	4	4	4	4	4	3	2
P02	SP	2	4	5	5	5	5	5	5	5	5	5	5	5	5	5	5	5	4	2	
	IN	2	3	5	5	5	5	5	5	5	5	5	5	5	5	5	5	5	5	3	2
P03	SP	3	5	6	6	6	6	6	6	6	6	6	6	6	6	6	6	6	4	3	2
	IN	3	4	6	6	6	6	6	6	6	6	6	6	6	6	6	6	6	6	4	3
P04	SP	2	3	5	6	5	6	5	6	5	6	5	6	5	6	5	6	5	6	4	2
	IN	2	3	5	6	4	6	4	6	4	6	4	6	4	6	4	6	4	6	5	3
P05	SP	3	3	4	4	4	5	5	5	5	5	5	6	6	6	6	6	6	5	4	3
	IN	2	2	3	3	3	4	4	4	5	5	5	6	6	6	7	7	7	6	4	3
P06	SP	3	4	4	5	5	6	6	6	7	7	7	6	6	6	5	5	4	4	3	2
	IN	1	3	4	4	5	5	6	6	7	7	7	6	6	5	5	4	4	3	3	2
P07	SP	5	5	6	6	7	6	6	6	7	6	7	6	7	6	7	6	7	6	5	5
	IN	3	3	4	4	6	4	6	4	6	4	6	4	6	4	6	4	6	5	4	4
P08	SP	3	4	5	6	7	5	6	7	5	6	7	5	6	7	5	6	7	6	5	4
	IN	2	3	4	5	6	4	5	6	4	5	6	4	5	6	4	5	6	5	4	3
P09	SP	3	3	4	6	7	7	7	7	7	7	7	7	7	7	7	7	6	4	3	3
	IN	2	2	3	4	5	5	5	5	5	5	5	5	5	5	4	3	2	2	1	1
P10	SP	5	5	6	6	8	8	5	5	8	8	5	5	8	8	5	5	6	6	5	5
	IN	3	3	4	4	5	5	2	5	5	2	5	5	2	5	5	2	5	5	4	3
P11	SP	4	4	5	5	5	6	6	6	7	8	8	7	6	6	6	5	5	5	4	4
	IN	1	1	1	2	2	2	3	3	3	4	4	3	3	3	2	2	2	1	1	1
P12	SP	3	3	3	6	5	6	8	6	8	7	8	6	6	5	5	4	5	7	4	3
	IN	2	4	2	6	3	6	4	4	5	2	6	3	6	2	6	2	5	4	6	1

## MP3 MUSIC



## CONSTITUTION TEST

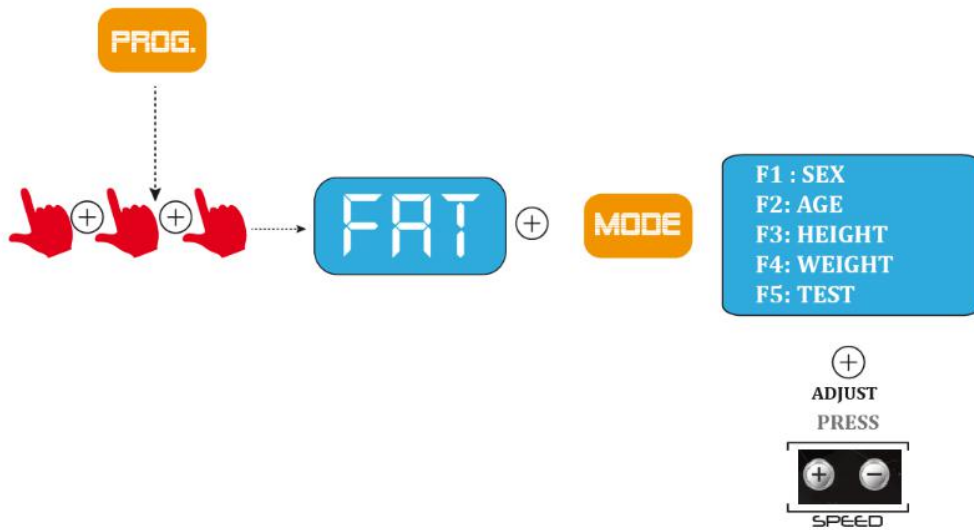

## VI. MAINTENANCE

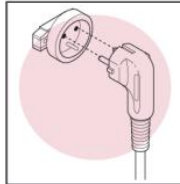
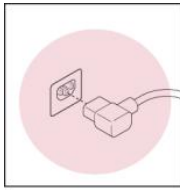

This product must be earthed. If the power cord is damaged, it must be replaced with a manufacturer recommended power cord.

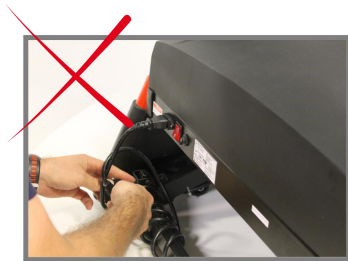

**DO NOT TANGLE THE POWER CORD**

### REGULAR MAINTENANCE OF THE TREADMILL

- **STORAGE:** Keep your equipment in a enclosed place, away from dust or humidity. Don't store it neither in a garage or in a indoor backyard, or near the water. Humidity, dust and water could damage it and have an effect on its functioning
- **ELECTRIC CABLE:** Make sure that the cable and plug are in perfect conditions. Electric cables must be away from hot surfaces
- **SCREWS AND CONNECTING CABLES:** Supervise and tighten the screws on a regular basis, because due to the vibration the screws and nuts tend to loosen.

**LUBRICATION:** It's a correct lubrication of the treadmill with silicon oil or Teflon is really important. This lubrication must be performed regularly depending on its use even before the first use. There is a hole for adding oil on motor cover. After starting machine, please change to highest speed, then add the oil into the hole, the oil will be spread from the middle between the running belt and board.

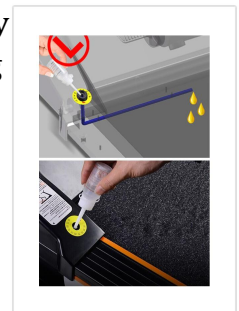

< 3 hours/week	2 months
4 - 7 hours/week	1 month
> 8 hours/week	15 days

- ALIGN AND TIGHTEN THE BELT OF THE TREADMILL**

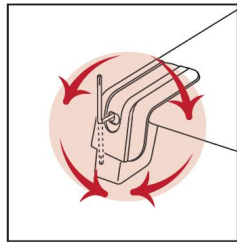

LEFT BOLT      RIGHT BOLT

- ALIGN THE BELT:** Due to its use, the belt can move off center. If the belt has moved to the left, start treadmill and increase the speed to 3MPH .Use the 6mm Wrench to turn the fixed left bolt clockwise or turn the fixed right bolt counterclockwise. Don't tighten the belt too much in order to be able to walk. Repeat this procedure until the belt is properly aligned.

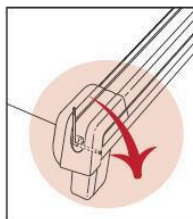
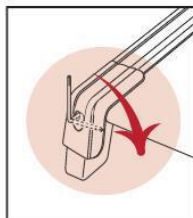
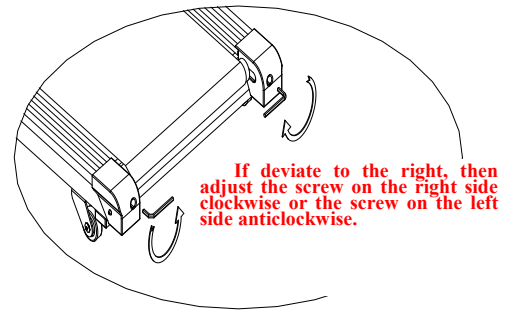
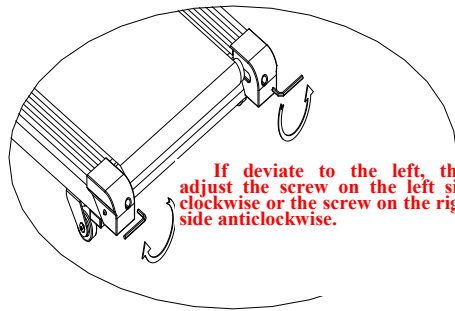

LEFT BOLT      RIGHT BOLT

- TIGHTEN THE BELT:** (if the belt slips on the treadmill when walking). Start treadmill and increase the speed to 3MPH.Using the 6mm Wrench , turn both bolts 1/4 clockwise. If the belt is properly tight to walk, you must be able to pull up each side of the belt 5 or 7 cm off the platform. Be careful and maintain the belt aligned. Repeat this procedure until the belt is properly tightened.

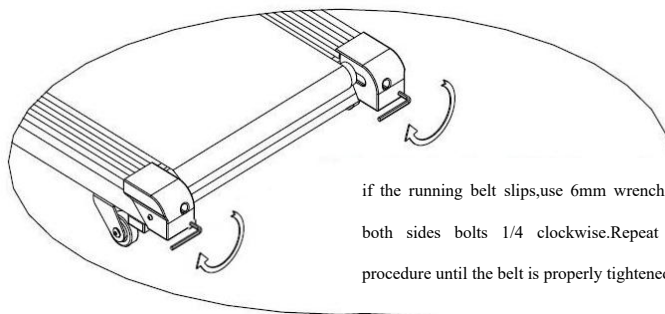

if the running belt slips,use 6mm wrench,turn both sides bolts 1/4 clockwise.Repeat this procedure until the belt is properly tightened.



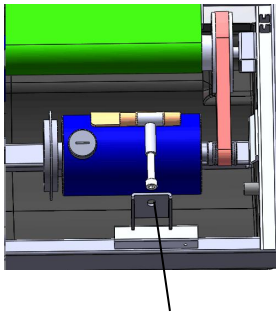

Adjusting bolt

- **TIGHTEN THE DRIVE BELT:**if the drive belt becomes loose after using for a period of time,you need to:
  - (1) Open the motor cover .
  - (2) Use the 6mm wrench to turn the adjusting bolt clockwise.
 Repeat this procedure until the drive belt is not slippery anymore.

- **CLEANING:** Don't use abrasive products. A damp cloth is enough.
- **LEVELING:** If your unit is provided with leveling wheels, please adjust them in order to avoid vibrations and therefore malfunctions.
- **KEEP THESE MAINTENANCE ADVISES FOR FUTURE REFERENCES**

## VII.RECYCLING INFORMATION

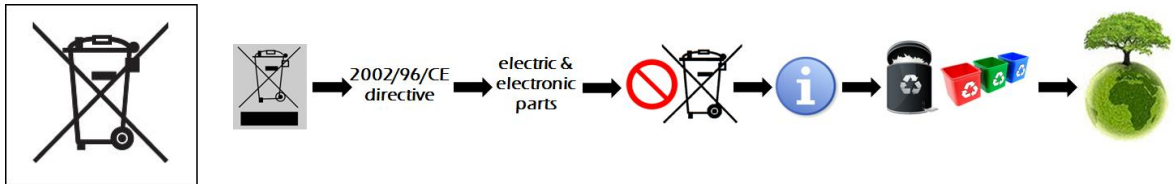

This electronic product must not be disposed of in municipal waste. To preserve the environment, this product must be recycled after its useful life as required by law.

## VIII.COMMON ERRORS :

ERRO CODE	REASON	HOW TO SOLVE
NO DISPLAY	A) electricity not connected	Connect the electricity
	B) power switch not turn on	Turn on power switch
	C) pcb no power or broken	Press over-load protector or change new pcb
	D) signal wire not connected	Re-connect signal wire or change new one
	E) computer broken	Change new computer

		F) background light broken	Check background light wire or change new one
NOT DISPLAY ALL		A) display drive IC not inserted	Re-insert IC, and re-weld it or change new one
		B) EMI gasket slip, not well	Re-assemble screen
NOT RUN SMOOTHLY		A) driving position has resistance	Adjust driving position, or add some silicon oil
		B) running belt too tight or too	Adjust the belt tension
		C) pcb torque too big or too small	Adjust torque to right position
---	OR	A) safety key off	Put on safety key
		B) magnetron not fixed well	Fix magnetron to right position
E01/E13		A) signal wire not well connected	Re-connect signal wire
		B) signal wire broken	Change new signal wire
		C) signal wire broken	Change new computer
		D) pcb broken	Change new pcb
E02		A) motor wire not well connected,	Re-connect motor wire or change new motor
		B) IGBT on pcb broken	Change new pcb
		C) input voltage too low	Stop using, ask electrician to check
E03		A) speed signal wire not well	Re-connect speed signal wire or change new
		B) pcb broken	Change new pcb
E04		A) incline motor wire not well	Re-connect incline motor wire
		B) incline motor broken	Change new incline motor
		C) pcb broken	Change new pcb
E05		A) over-loaded	Turn off and re-start machine
		B) driving position hinder	Adjust driving position, or add oil
		C) motor short circuit	Change new motor
		D) pcb burnt	Change new pcb
E06		A) motor wire not well connected	Re-connect motor wire
		B) motor open circuit	Change new motor
		C) motor idling	Re-assemble to test
E08		A) storage IC not well inserted	Re-insert IC, pay attention to pins
		B) storage IC broken, or pcb	Change new IC, or change new pcb
E09		A) machine stand or not put	Put evenly on floor
		B) pcb broken	Change new pcb
E10		A) pcb torque too big	Adjust torque to right position
		B) motor short circuit	Change new motor
		C) driving position hinder	Adjust driving position, or add oil
E11		Input voltage too big	Stop using, ask electrician to check
E14		Input voltage too low	Stop using, ask electrician to check



**A correct lubrication of the treadmill with silicon oil or Teflon is REALLY IMPORTANT. This lubrication MUST BE PERFORMED REGULARLY DEPENDING ON EACH PERSON, EVEN BEFORE ITS FIRST USE.**

**YOU MUST PRESERVE THE ORIGINAL PACKAGING WITH ITS PROTECTIONS, PURCHASE RECEIPT, MANUAL AND COMPONENTS DURING THE GUARANTEE PERIOD**

## **IX.WARRANTY**

We have one year quality warranty to the products. Within the warranty period, we provide the FREE replacement parts. If caused by incorrect assembly, incorrect use or change of parts failures, our company takes no responsibility. You should show our products series no. and relative pictures or information before getting the warranty.

This treadmill is only for home use, if the problems occurred by commercial used, our company takes no responsibility.

**IF you have any questions or problems,**

**please email us: [umay1123@outlook.com](mailto:umay1123@outlook.com)**

**You can also call us: +1 360-663-4482**

**You can also contact us through Skype: +1 360-663-4482**

**you can also leave your phone number to the same email address to consult us.**