

Instruction Manual

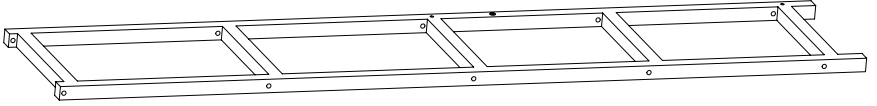

PARTS LIST

A x 1



B x 1

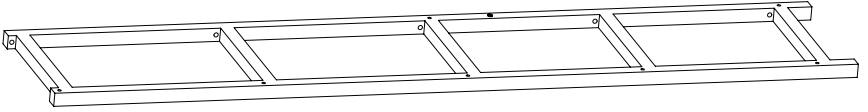

C x 1



D x 2



E x 5



F x 3

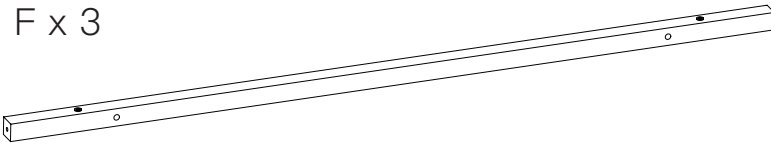

G x 2

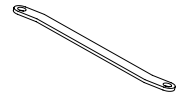

H x 2

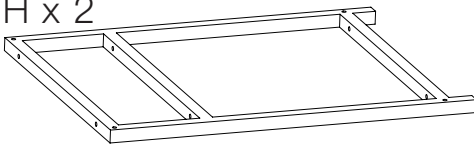

I x 2

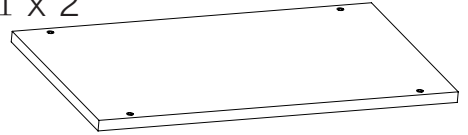

J x 5

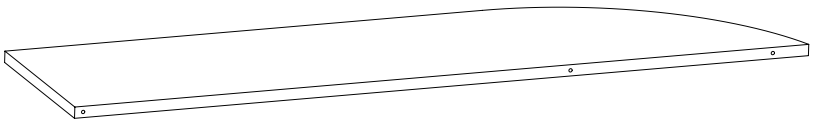

K x 1

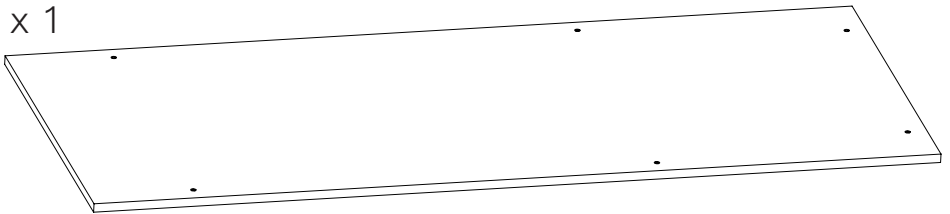

L x 9

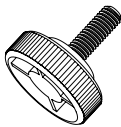

M (M6x10) x 4



N (M6x35) x 14

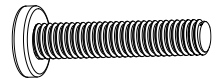

O (M6x40) x 20



P (M6x47) x 25

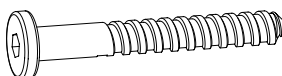

Q

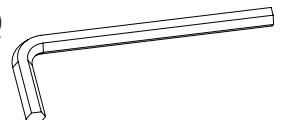

ASSEMBLY OVERVIEW

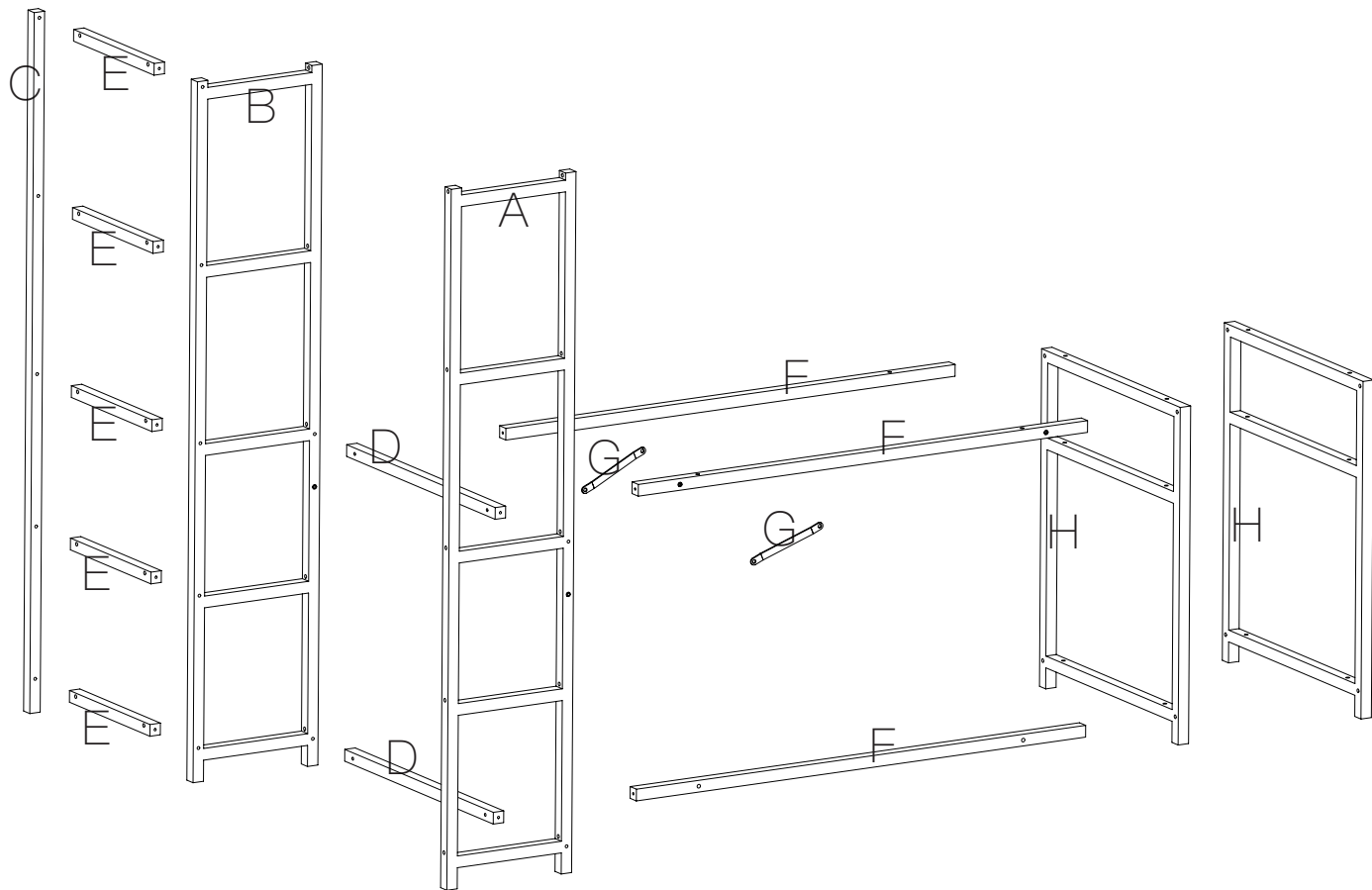

Step 1

Pay attention to the position and direction of components , especially screw holes

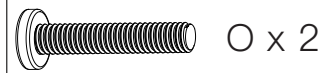
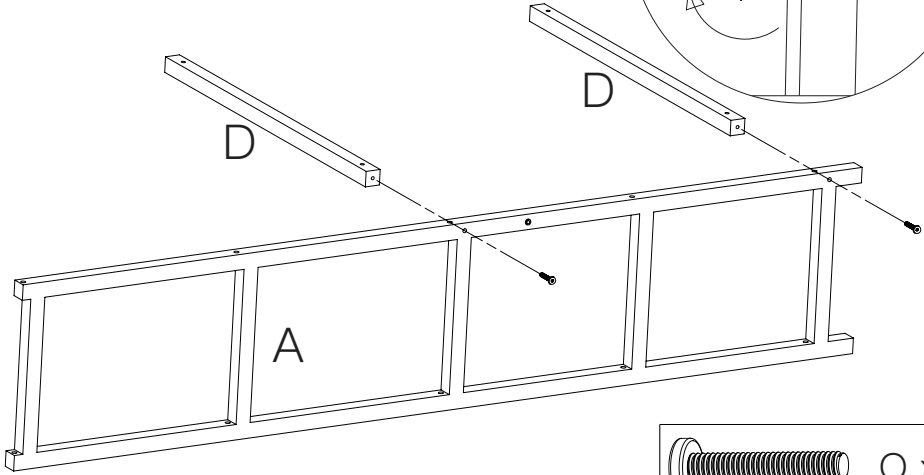
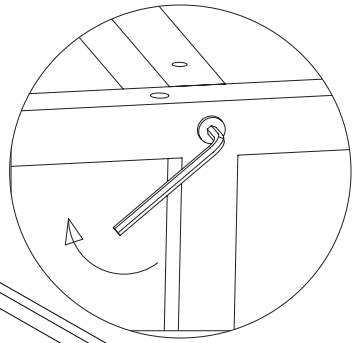

Step 2

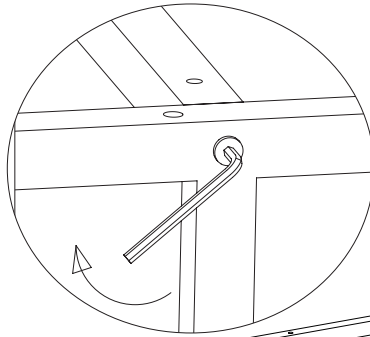

Do not over-tighten the bolts/screws

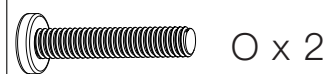
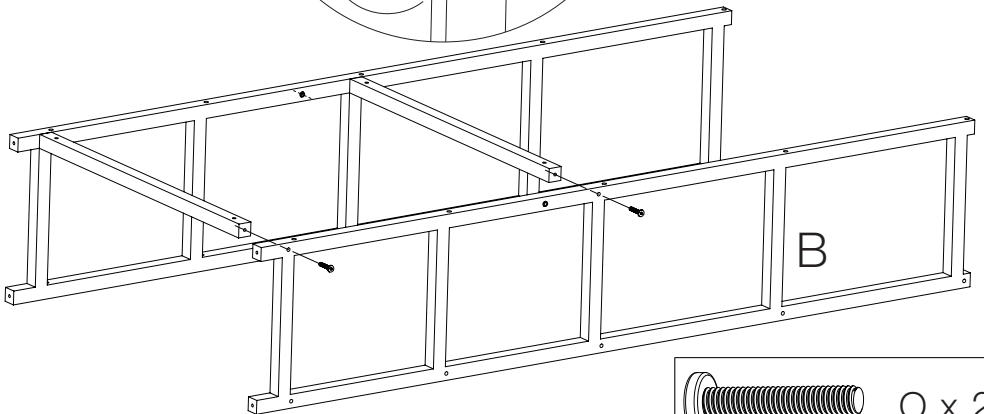

Step 3

Pay attention to the holes at Part E ,
refer to Step 11 and 12

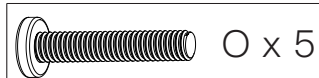
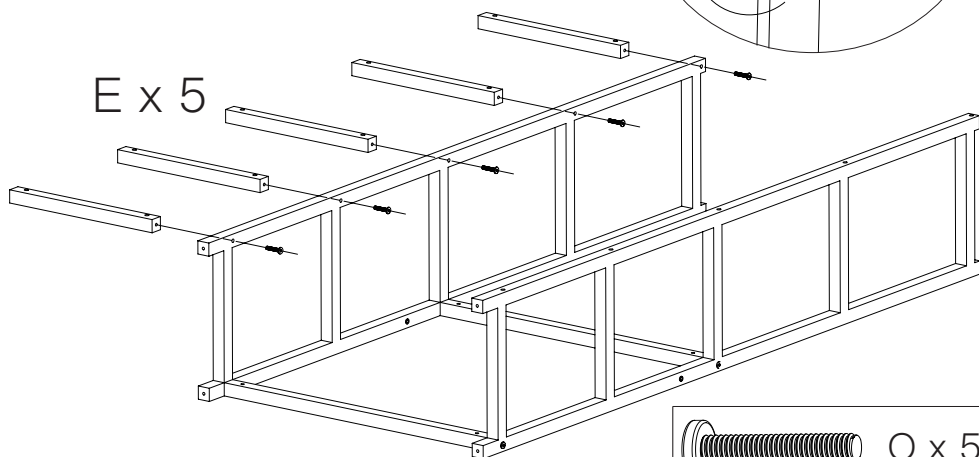
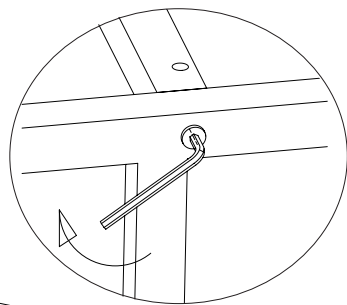

Step 4

Refer to Step 5 ,
ensure correct installation .

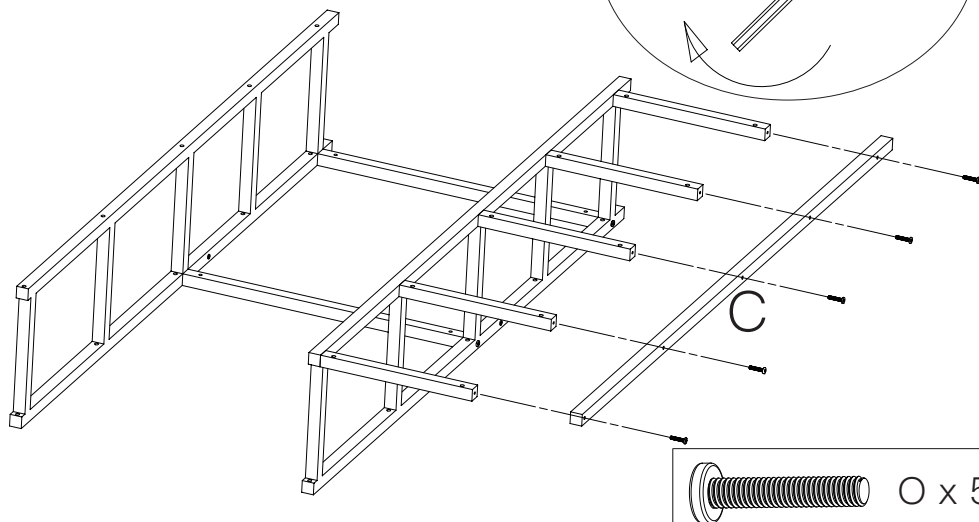
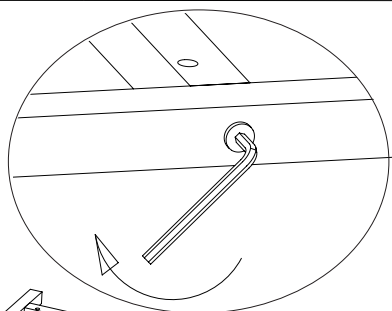

Step 5

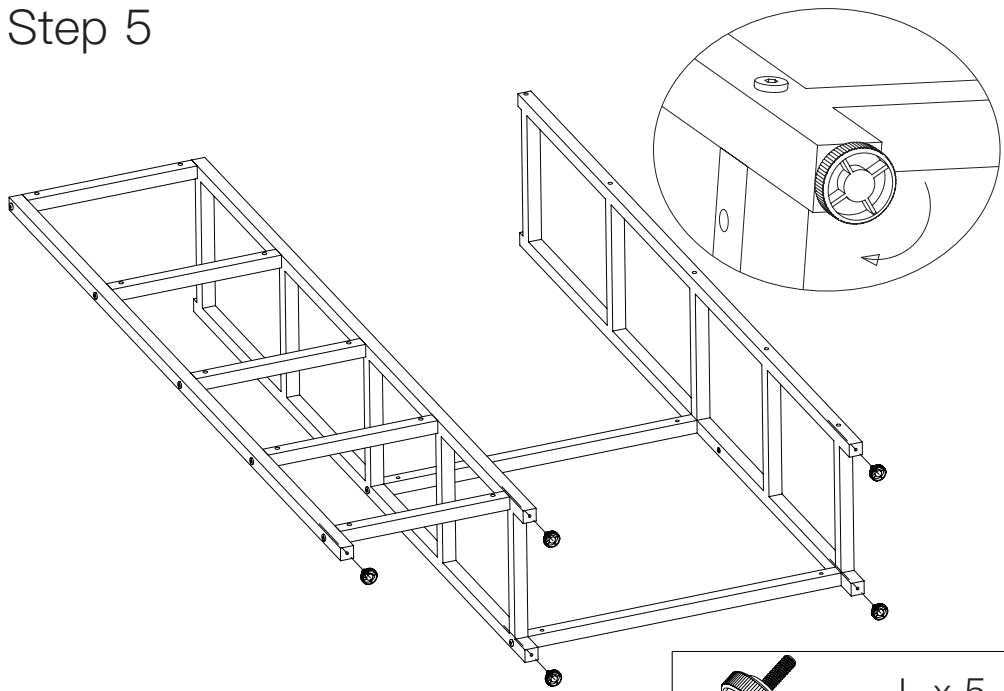

Step 6

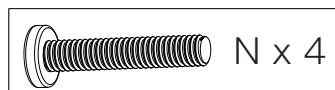
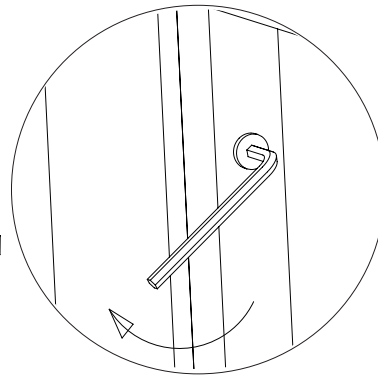
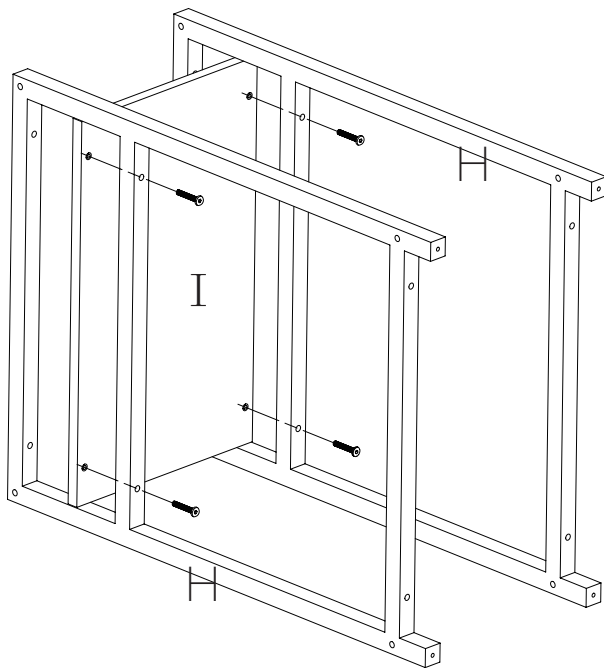

Step 7

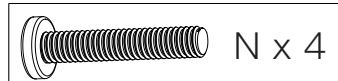
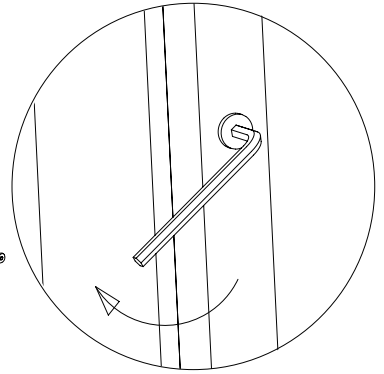
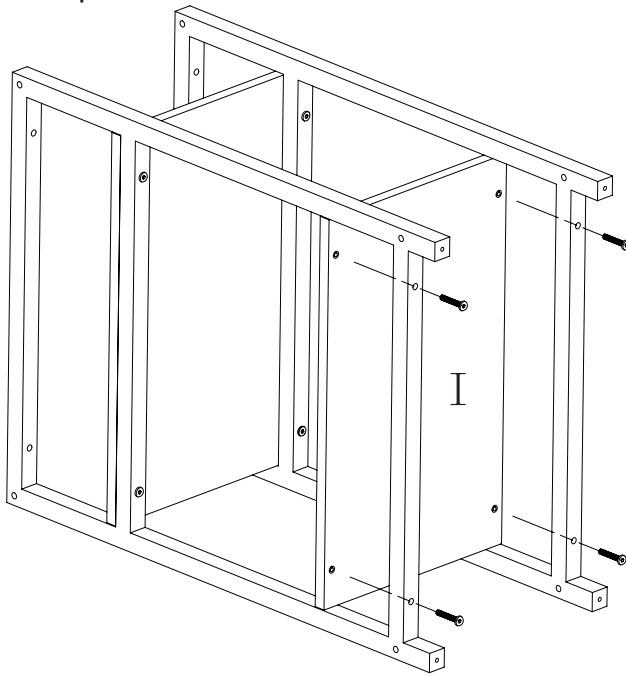

Step 8

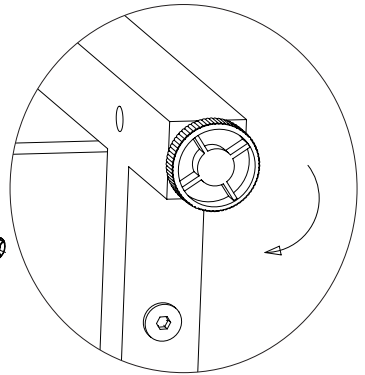
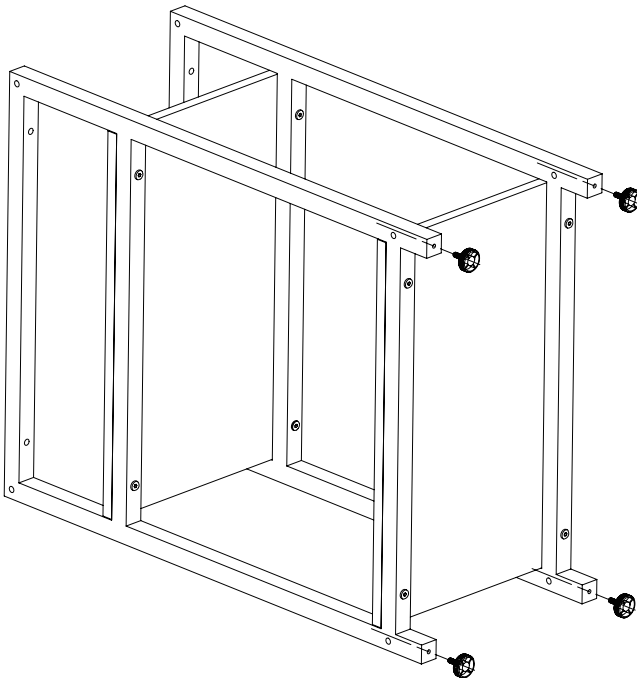

Step 9

Refer to three views and Step 11, pay attention to holes of Part F and ensure correct installation

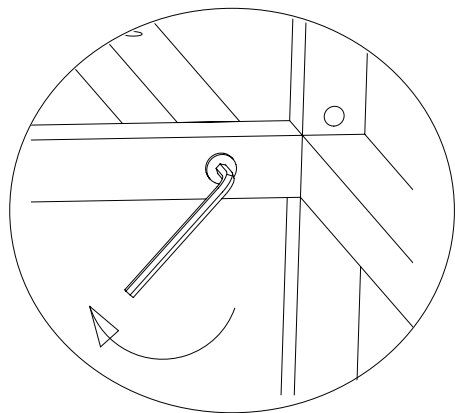
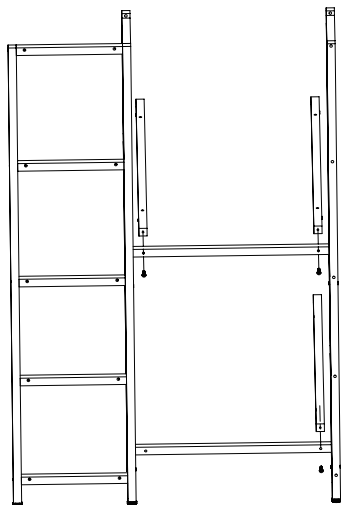
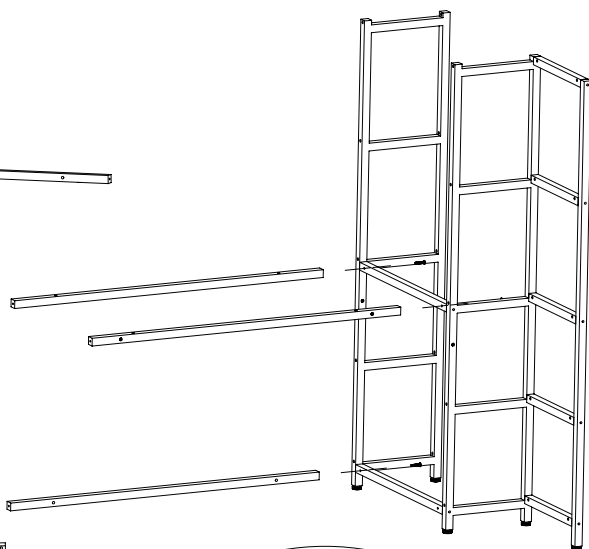
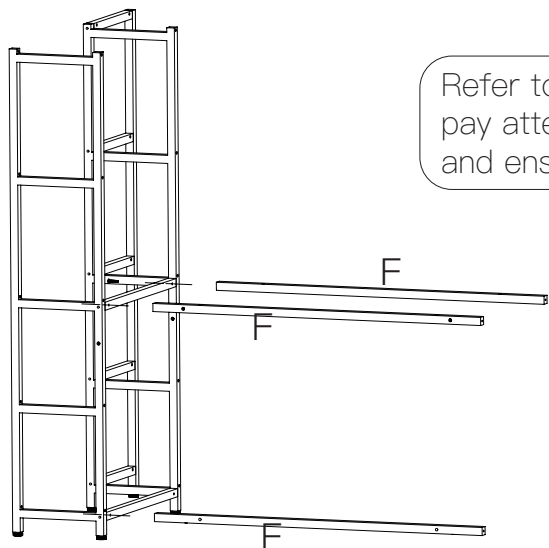

O x 3

Step 10

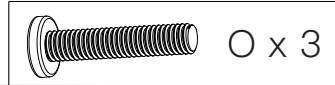
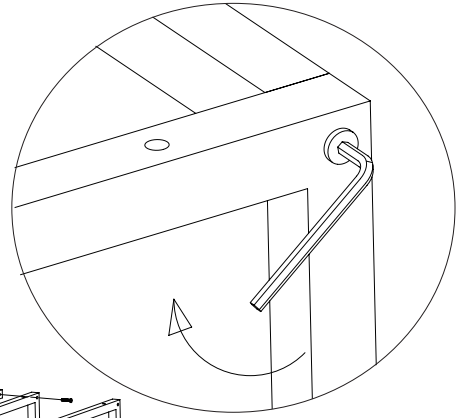
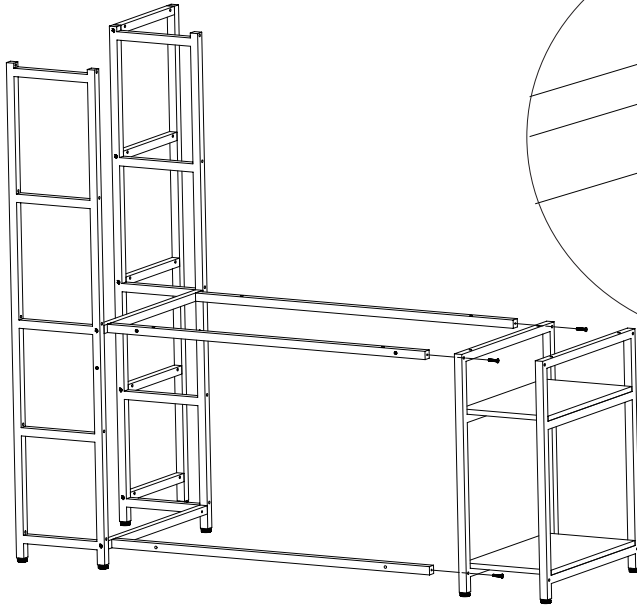

Step 11-(1)

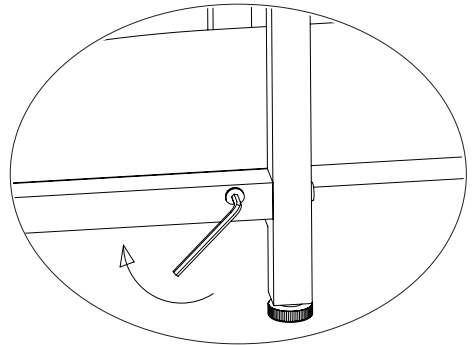
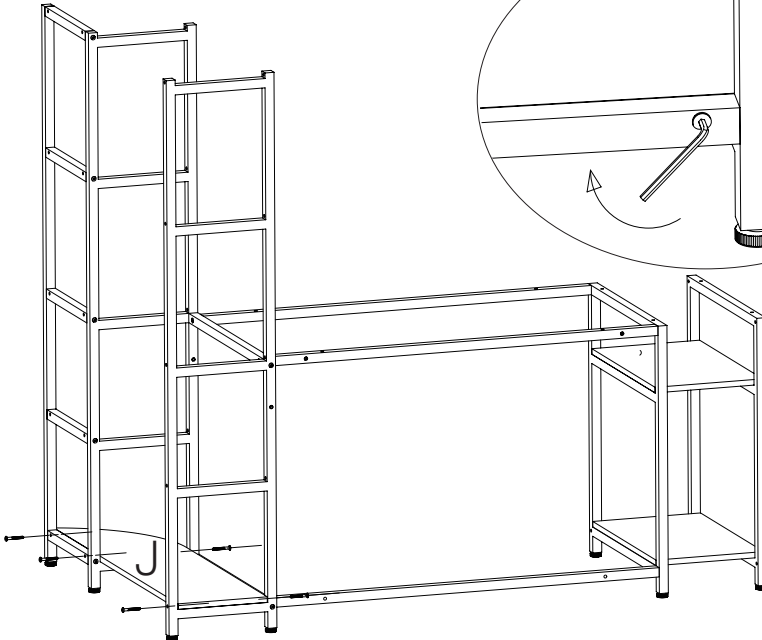

Step 11-(2)

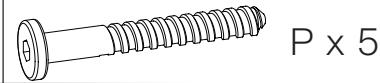
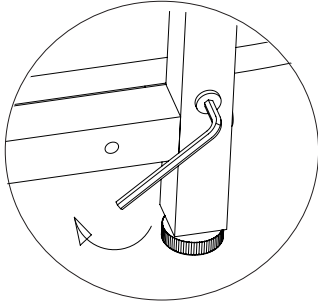
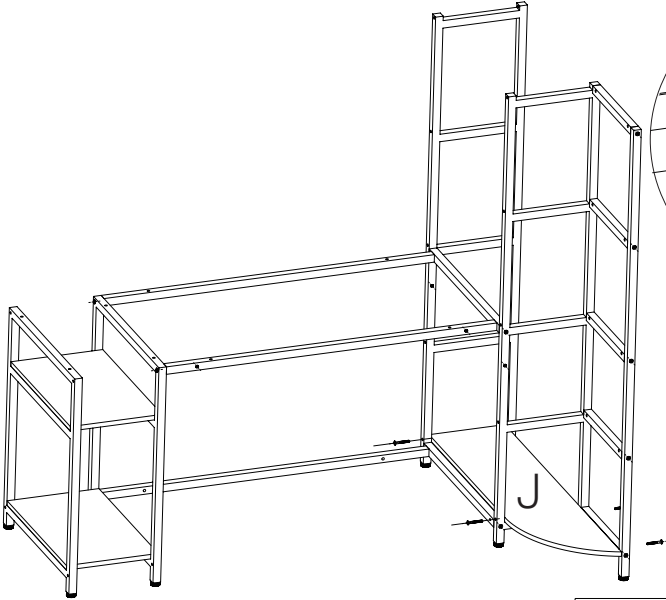

Step 12

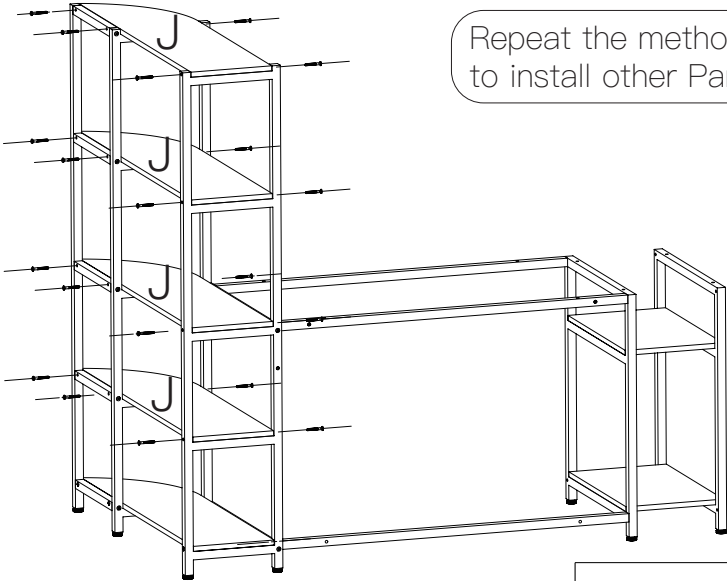

Repeat the method of Step 11 to install other Part J .

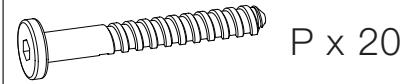

Step 13

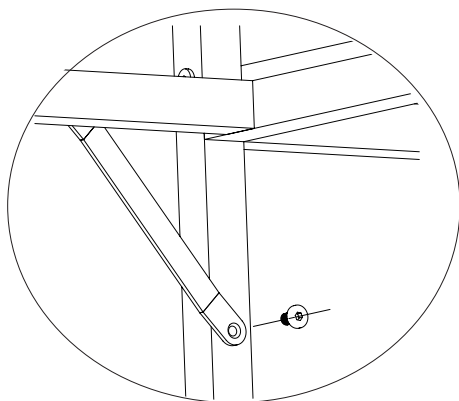
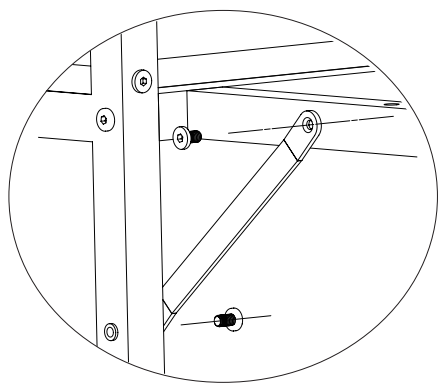
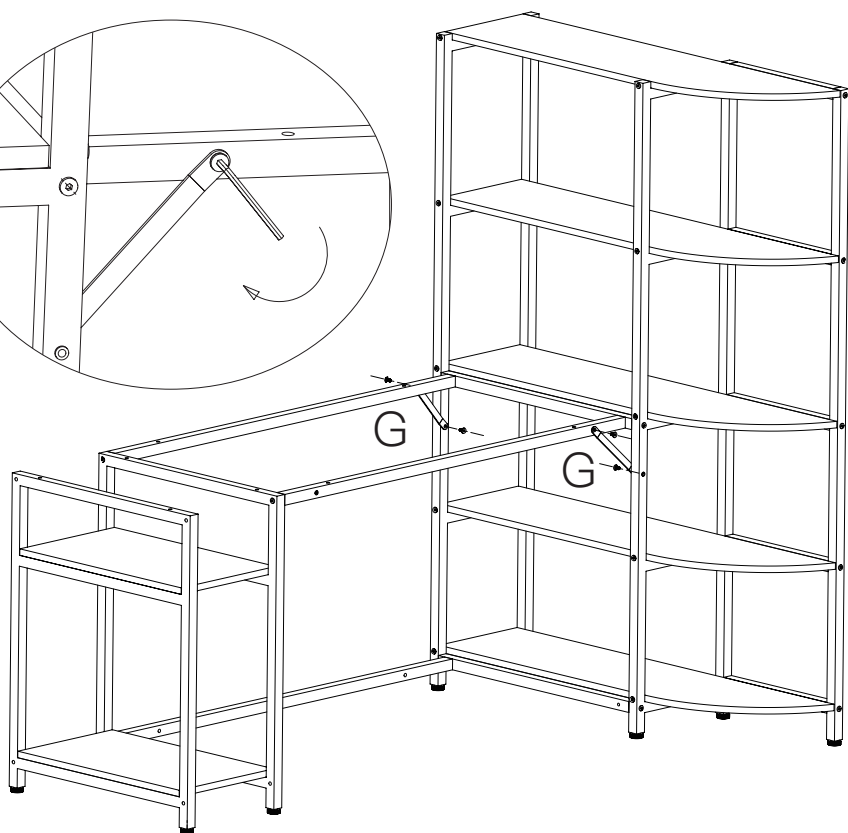
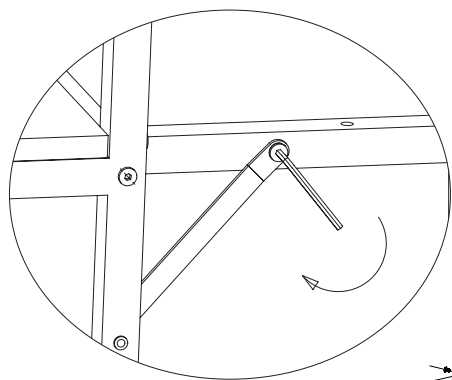

M x 4

Step 14

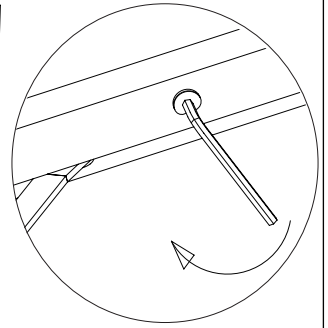
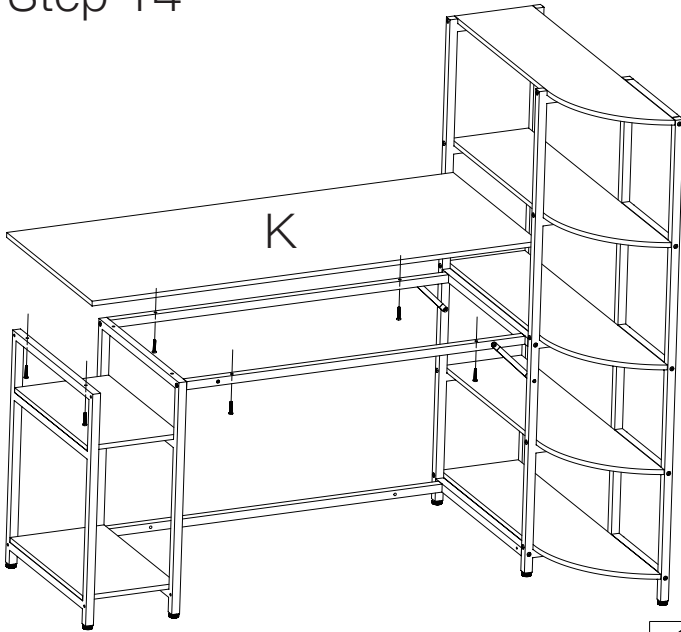

N x 6

ASSEMBLE ACCOMPLISHED

