

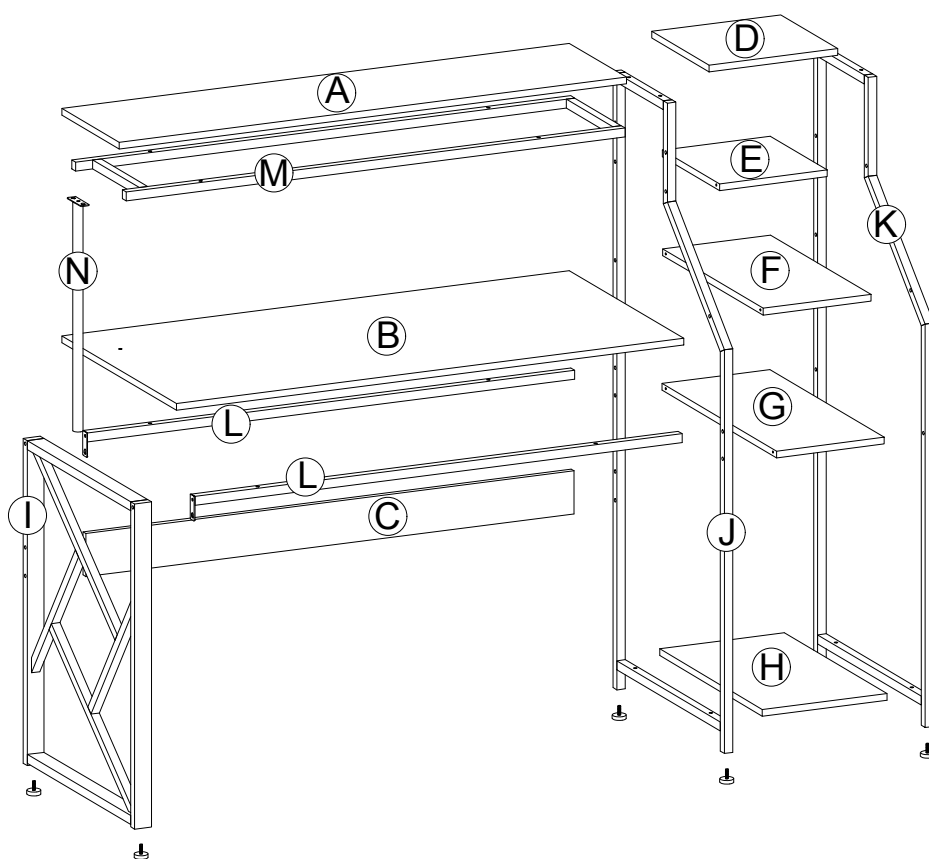

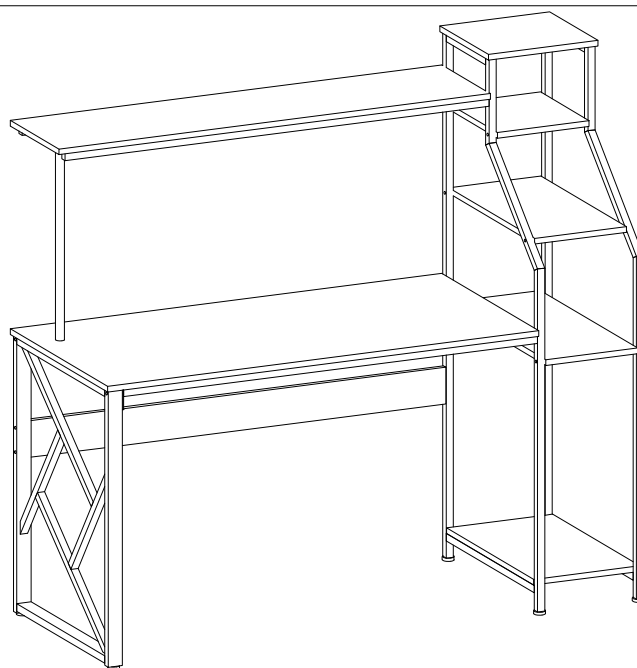





ASSEMBLY INSTRUCTIONS



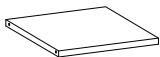
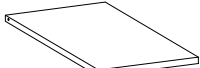
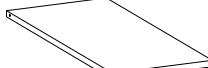
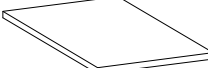
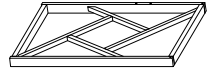

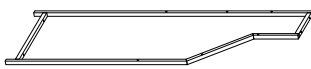

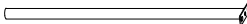

SKU: WF194327



Part List

| | | | |
|---|---|--|---|
|  |  |  |  |
| A×1pc | B×1pc | C×1pc | D×1pc |
|  |  |  |  |
| E×1pc | F×1pc | G×1pc | H×1pc |
|  |  |  |  |
| I×1pc | J×1pc | K×1pc | L×2pcs |
|  |  | | |
| M×1pc | N×1pc | | |

Hardware List

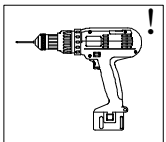

| | | | |
|---|---|--|---|
|  |  |  |  |
| M6×12mm | M6×30mm | M6×40mm | M6×50mm |
| ①×4pcs | ②×17pcs | ③×4pcs | ④×2pcs |
|  |  |  |  |
| ∅7×47mm | ∅7×70mm | | M4 |
| ⑤×14pcs | ⑥×2pcs | ⑦×6pcs | ⑧×1pc |

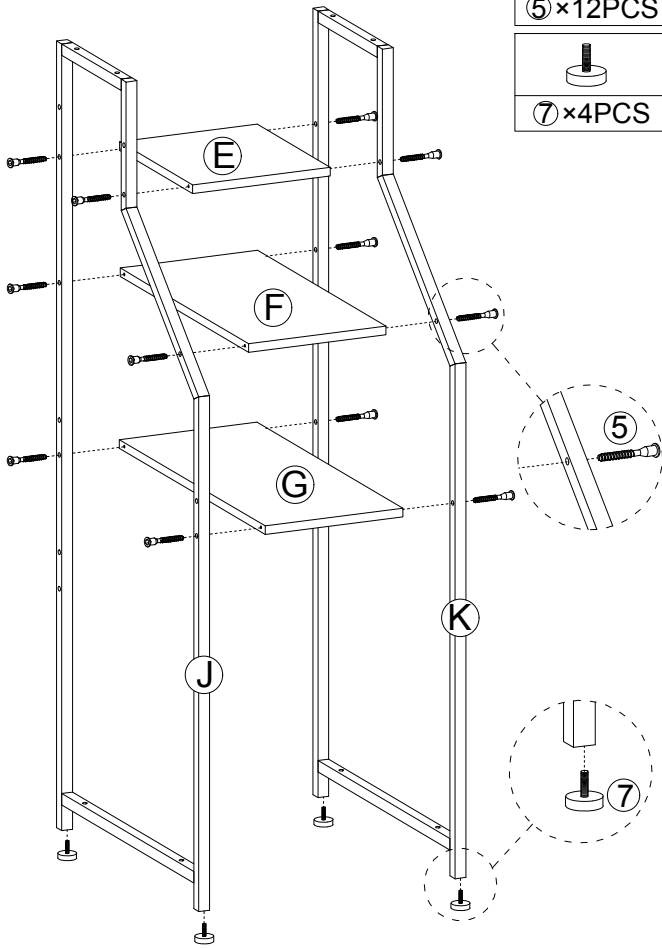

PLEASE BE CAREFUL DO NOT DAMAGE THE HOLE POSITION WHEN YOU USE POWER TOOLS !

Step 1



-  $\text{\O}7 \times 47\text{mm}$
- ⑤** $\times 12\text{PCS}$
- 
- ⑦** $\times 4\text{PCS}$



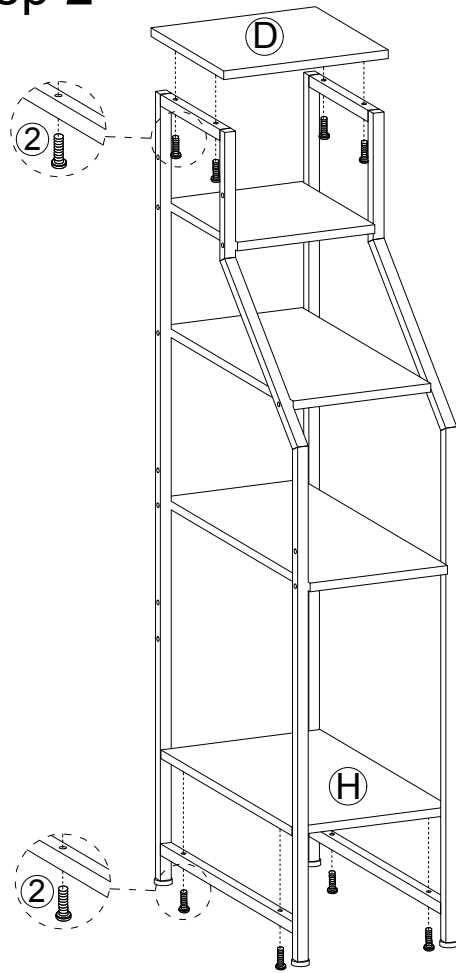



Step 2

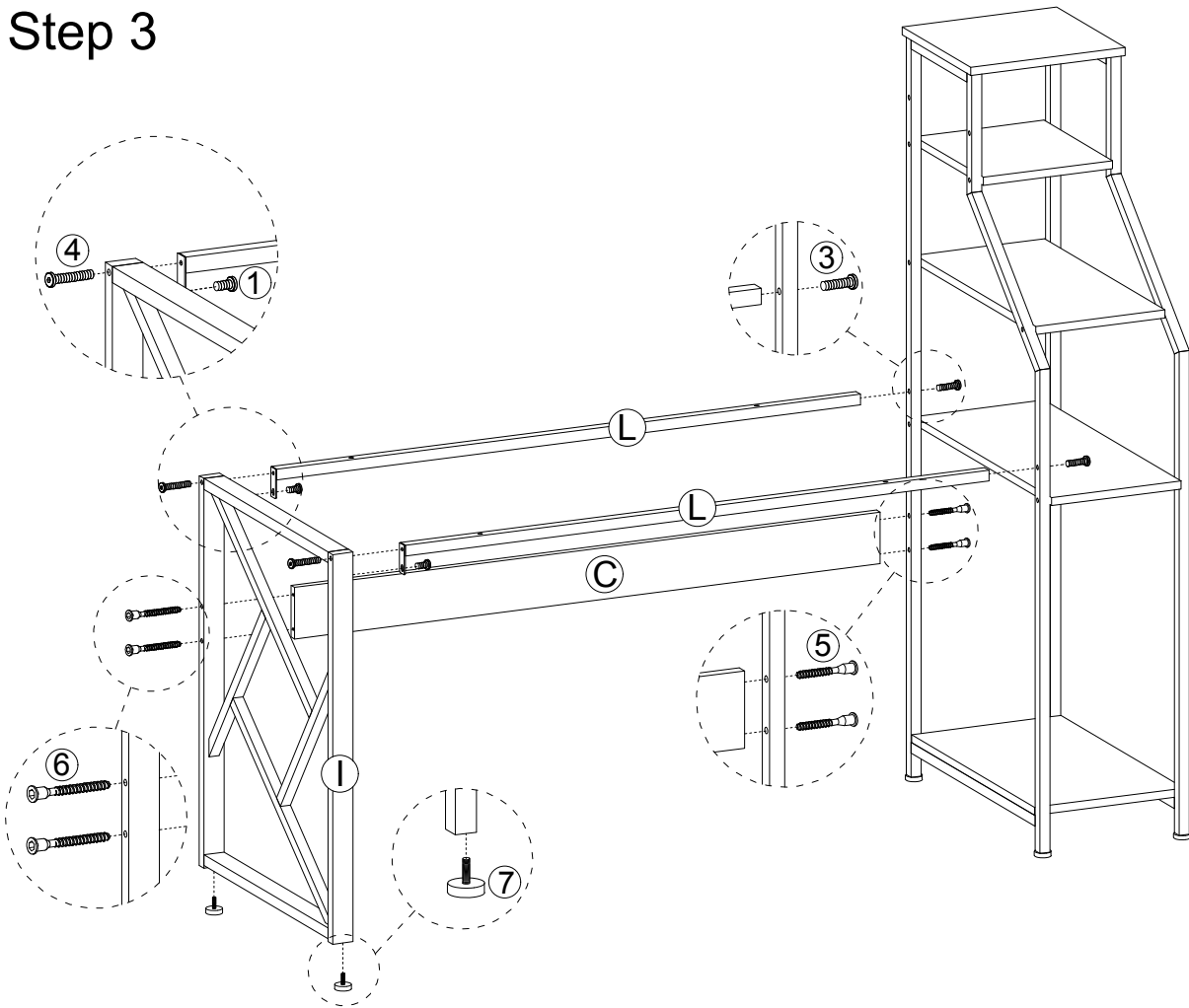

-  $\text{M6} \times 30\text{mm}$
- ②** $\times 8\text{PCS}$

Step 3



-  $\text{M6} \times 12\text{mm}$
- ①** $\times 2\text{PCS}$
-  $\text{M6} \times 40\text{mm}$
- ③** $\times 2\text{PCS}$
-  $\text{M6} \times 50\text{mm}$
- ④** $\times 2\text{PCS}$
-  $\text{\O}7 \times 47\text{mm}$
- ⑤** $\times 2\text{PCS}$
-  $\text{\O}7 \times 70\text{mm}$
- ⑥** $\times 2\text{PCS}$
- 
- ⑦** $\times 2\text{PCS}$

Step 4

M6×30mm
②×4PCS

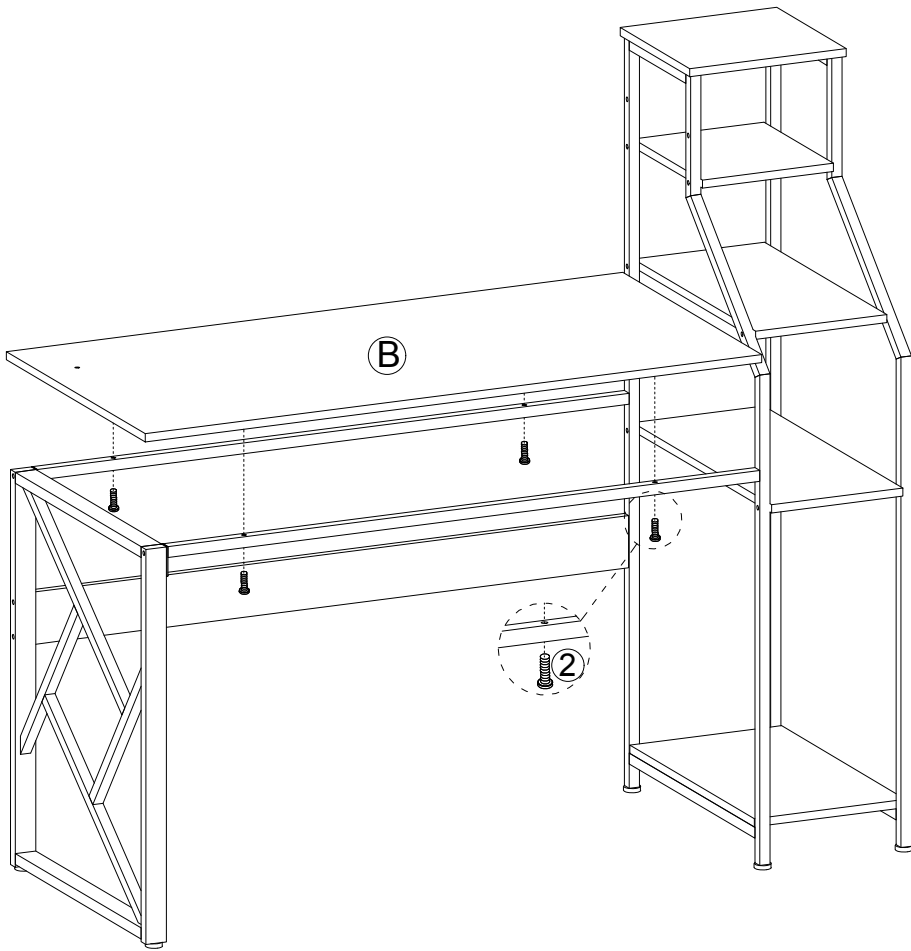

Step 5

M6×30mm
②×1PC

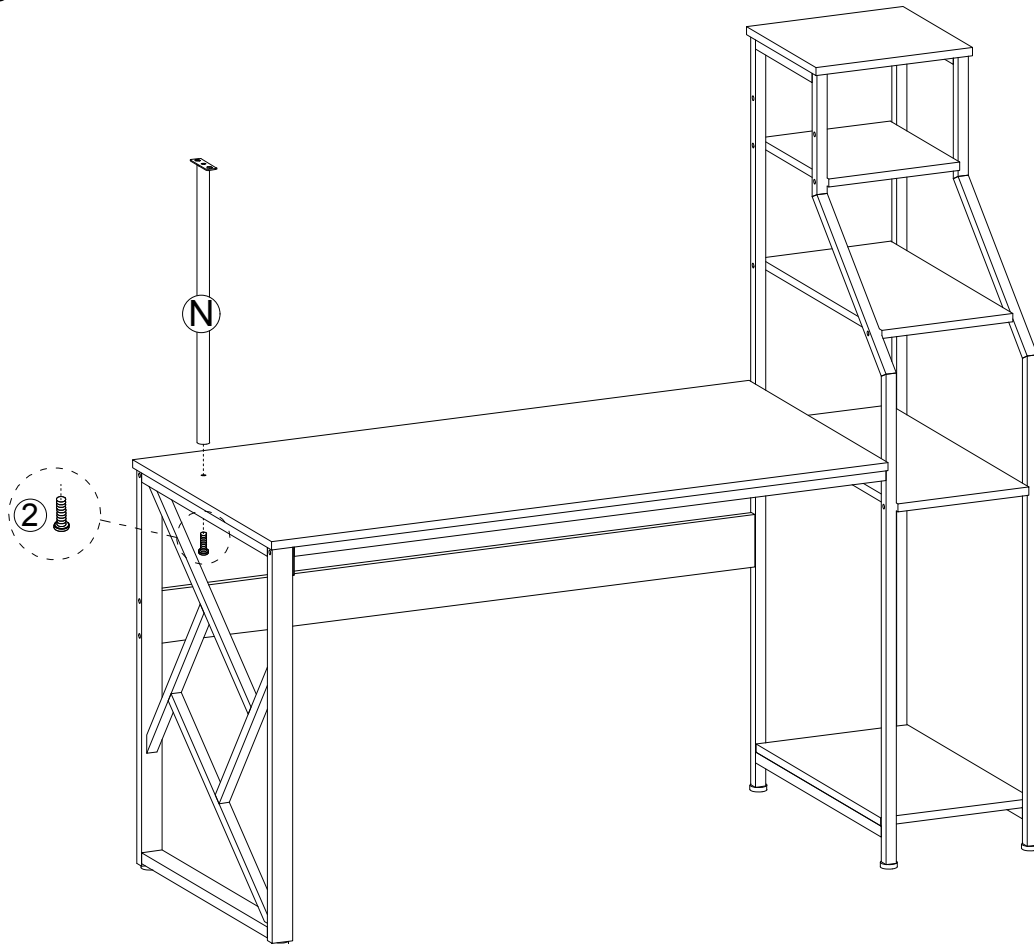

Step 6

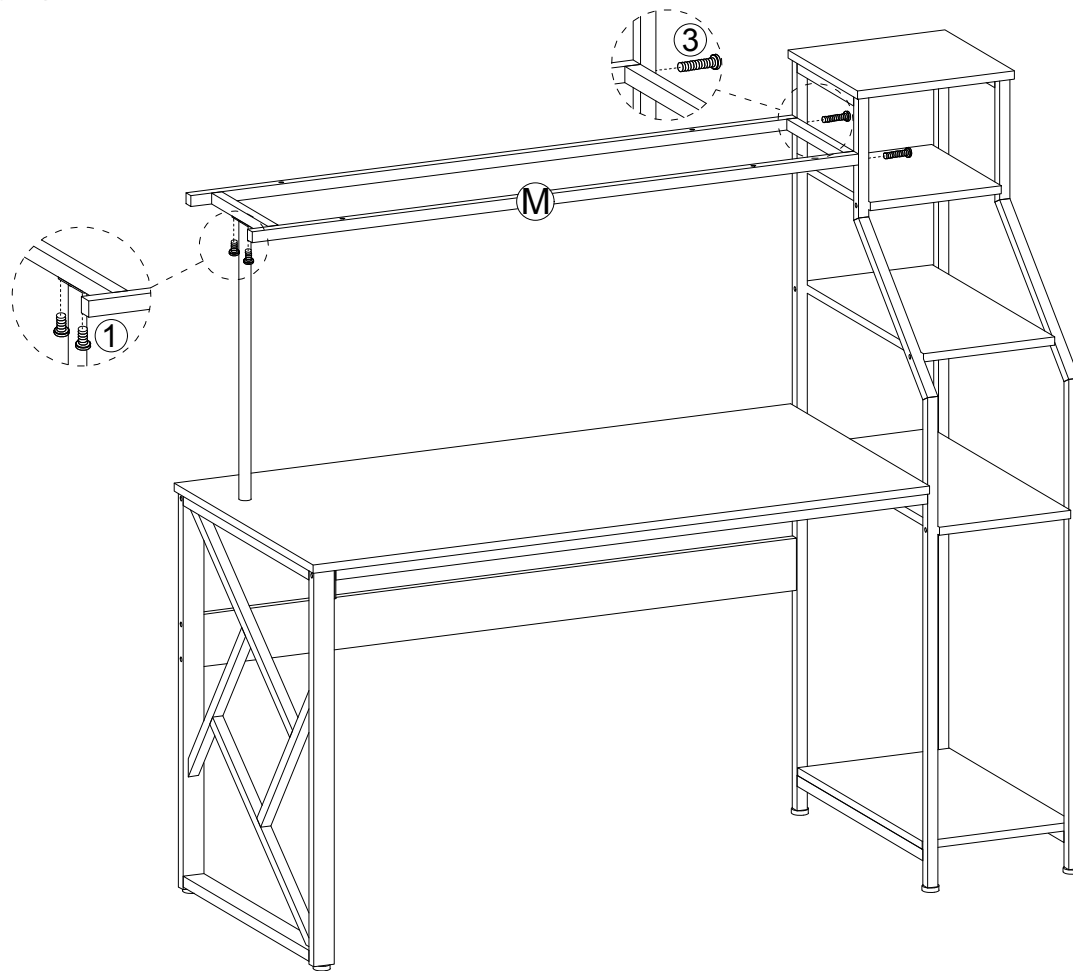

- M6×12mm
①×2PCS
- M6×40mm
③×2PCS

Step 7

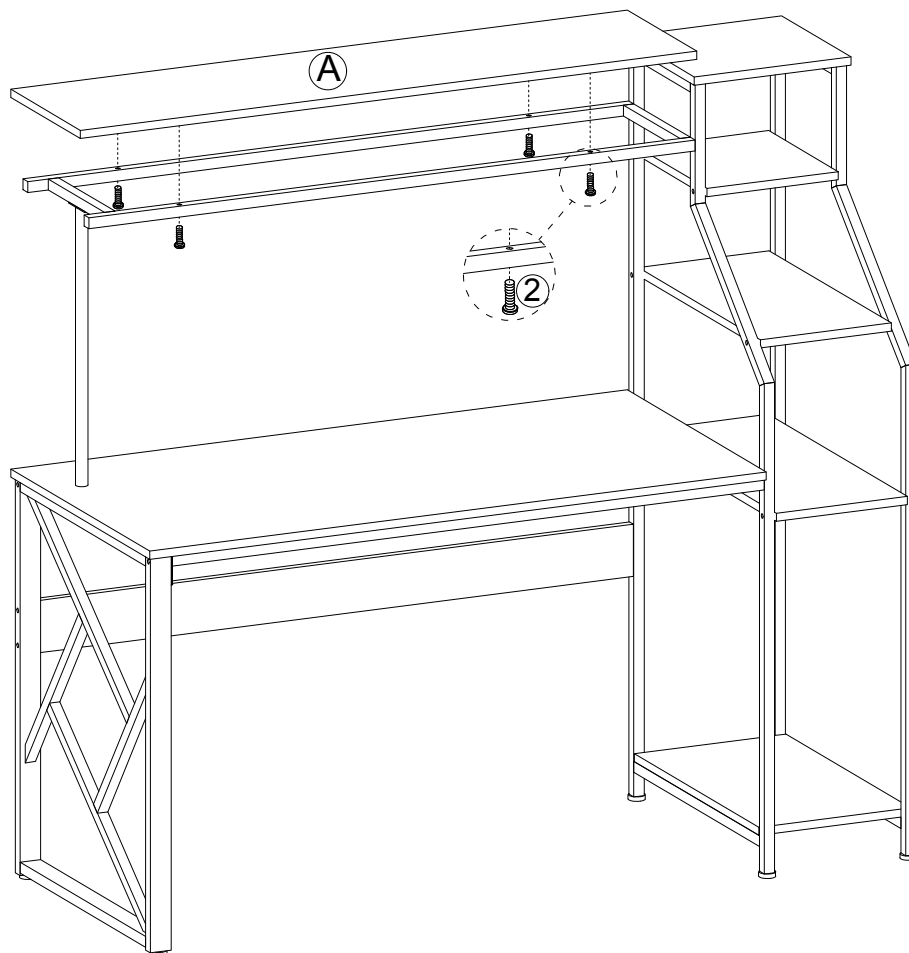

- M6×30mm
②×4PCS