

# ASSEMBLY INSTRUCTIONS

ITEM NO.WF212559

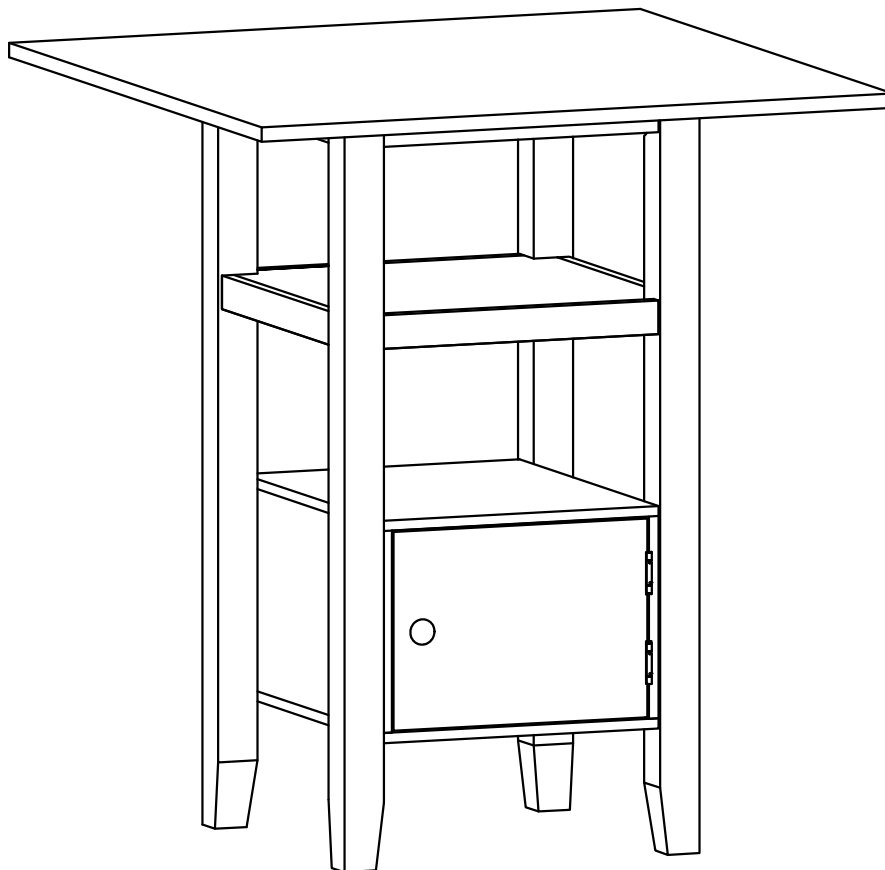



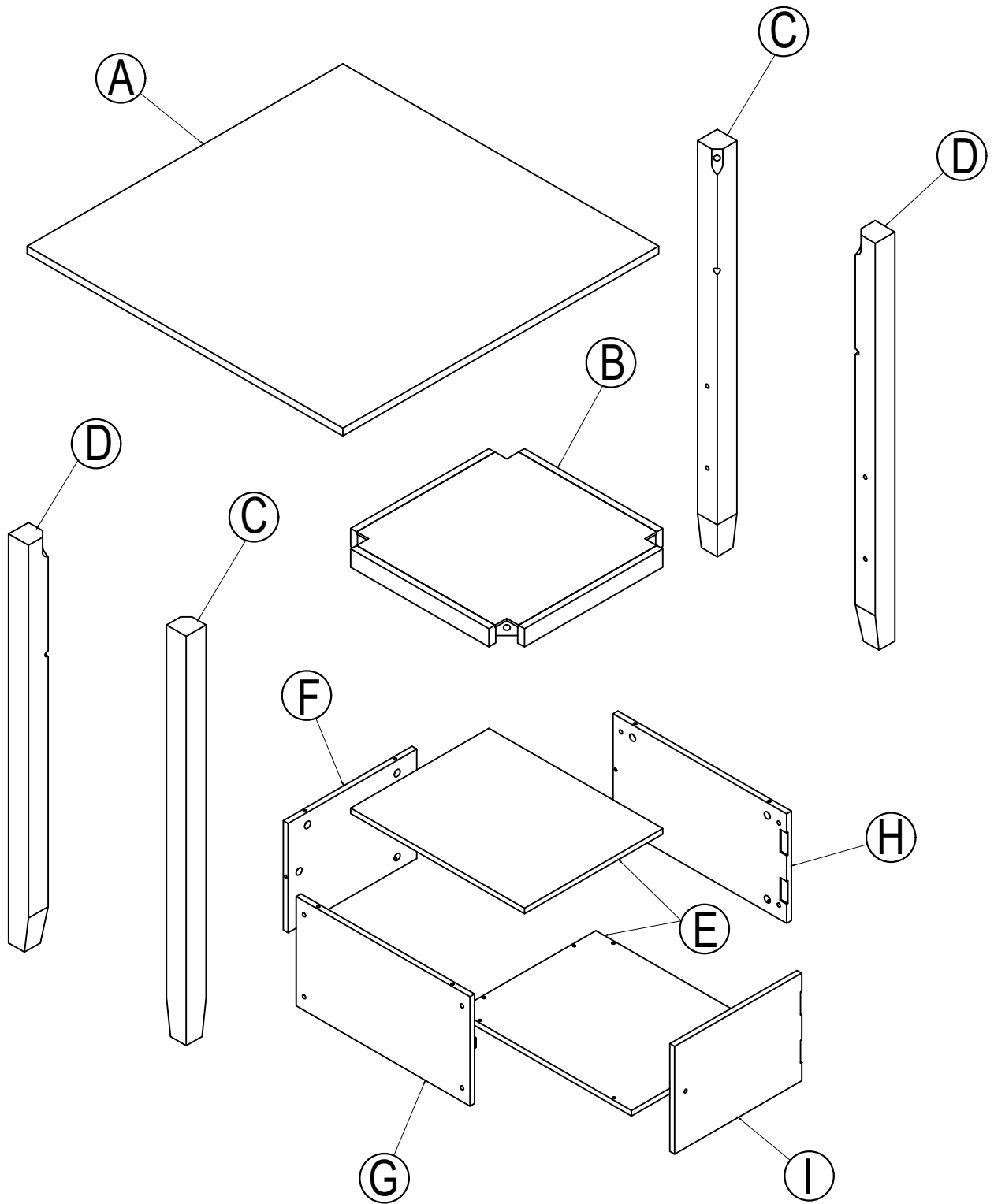

## IMPORTANT NOTE :

- ① PLACE ALL PARTS ON A CLEAN AND SMOOTH SURFACE SUCH AS A RUG OR CARPET TO AVOID THE PARTS FROM BEING SCRATCHED.
- ② BEFORE YOU BEGIN,KINDLY FOLLOW THE ASSEMBLY INSTRUCTIONS STEP BY STEP.
- ③ DO NOT TIGHTEN ALL SCREWS AND BOLTS UNTIL THE CHAIR IS FULLY SET-UP.

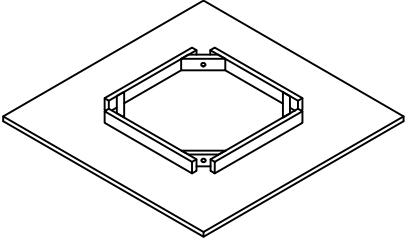
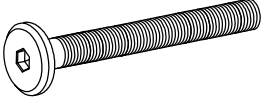
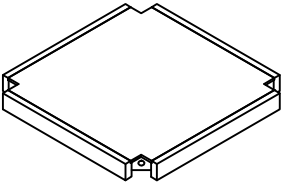
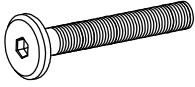
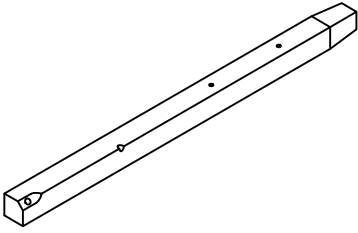

# Part List

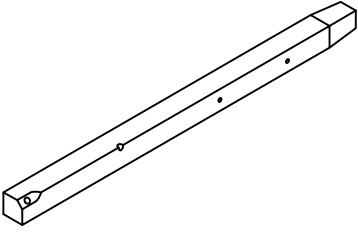
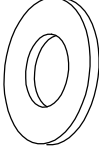
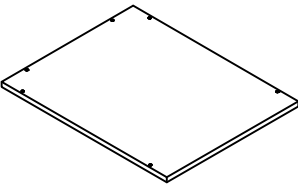
# Hardware List

|   |   |
|---|---|
| <p>(A)</p>  <p>TABLE TOP (1 pc)</p>        | <p>(1)</p>  <p>Ø 5/16" x 50 mm</p> <p>BOLT (8 pcs)</p>         |
| <p>(B)</p>  <p>TABLE SHELVES (1 pcs)</p>   | <p>(2)</p>  <p>Ø 1/4" x 30 mm</p> <p>BOLT (8 pcs)</p>          |
| <p>(C)</p>  <p>LEG LEFT (2 pcs)</p>      | <p>(3)</p>  <p>Ø5/16" x 13 mm</p> <p>FLAT WASHER (8 pcs)</p> |
| <p>(D)</p>  <p>LEG RIGHT (2 pcs)</p>     | <p>(4)</p>  <p>Ø5/16" x 19 mm</p> <p>LOCK WASHER (8 pcs)</p> |
| <p>(E)</p>  <p>BOX TOP PANEL (2 pcs)</p> | <p>(5)</p>  <p>4 mm</p> <p>ALLEN KEY (1pc)</p>               |

# Part List

# Hardware List

Ⓕ

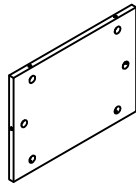

BOX BACK PANEL (1 pc)

Ⓖ

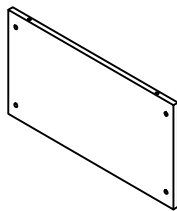

LEFT BOX SIDE PANEL (1 pc)

Ⓖ

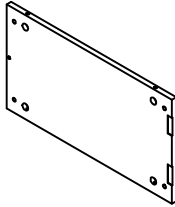

RIGHT BOX SIDE PANEL (1 pc)

Ⓖ

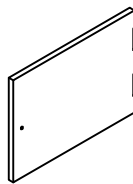

BOX FRONT DOOR (1 pc)

Ⓖ



15 x 9 mm

CAM LOCK (14 pcs)

Ⓖ

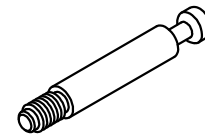

6.5 x 35 mm

CAM BOLT (14 pcs)

Ⓖ

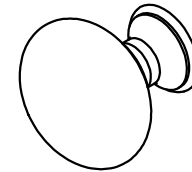

4 x 26 x 28 mm

HANDLE (1 pc)

Ⓖ



Ø4 x 20 mm

HANDLE SCREW (1 pc)

Ⓖ

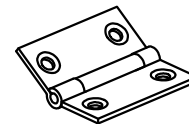

38 x 32 x 1.5 mm

DOOR HINGE (2 pcs)

Ⓖ



Ø 3 x 10mm

WOOD SCREWS (8 pcs)

# STEP 1:

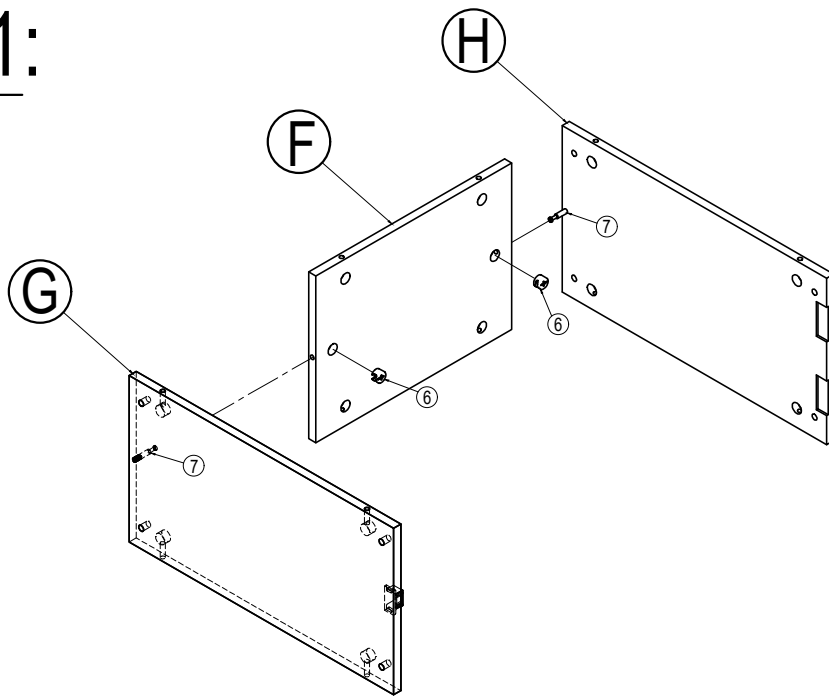

# STEP 2:

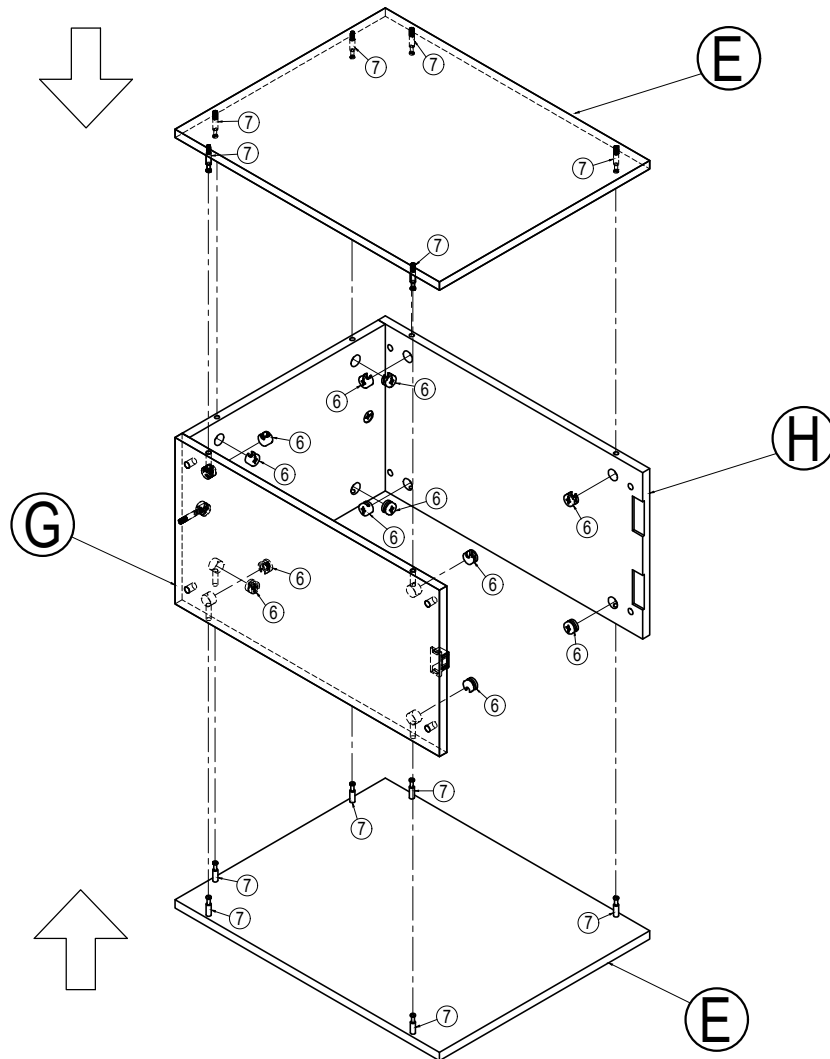

# STEP 3:

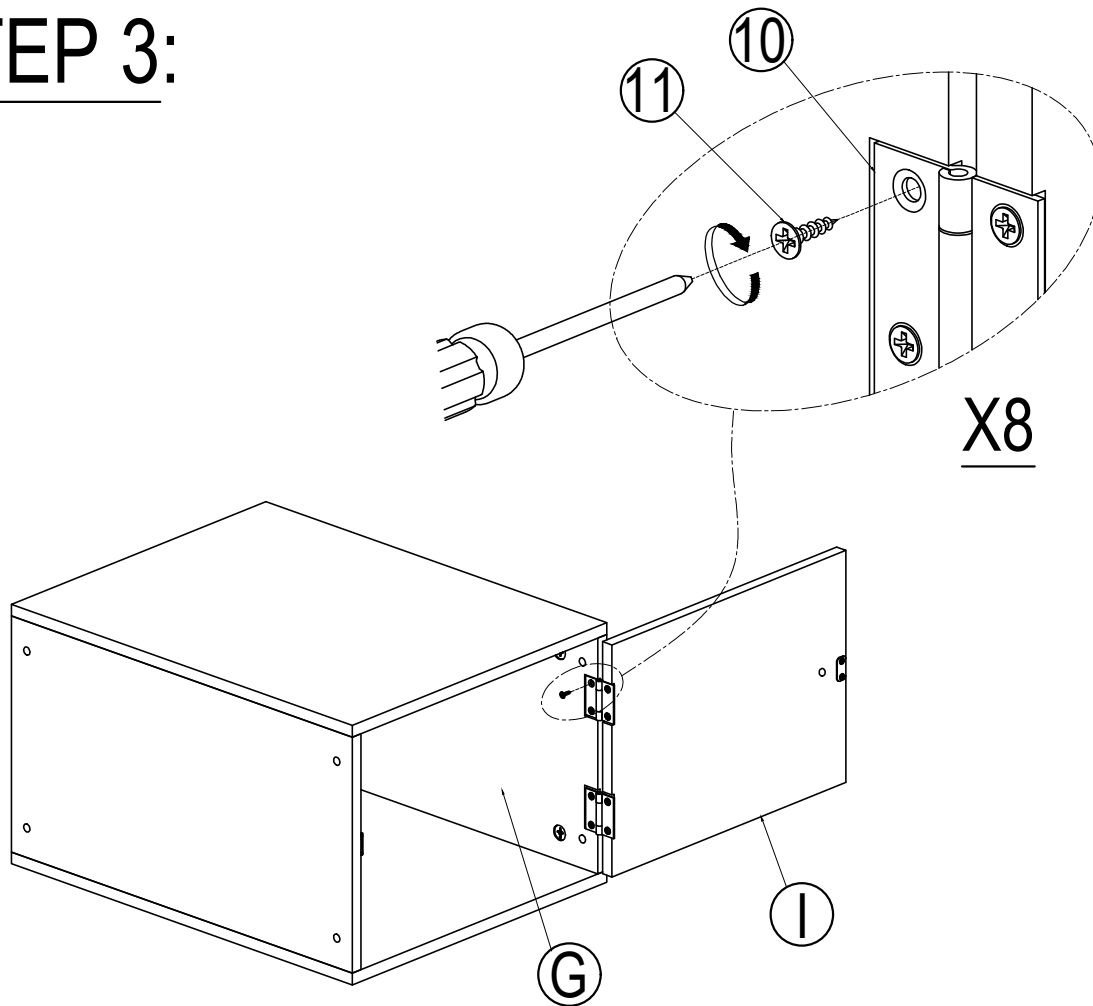

# STEP 4:

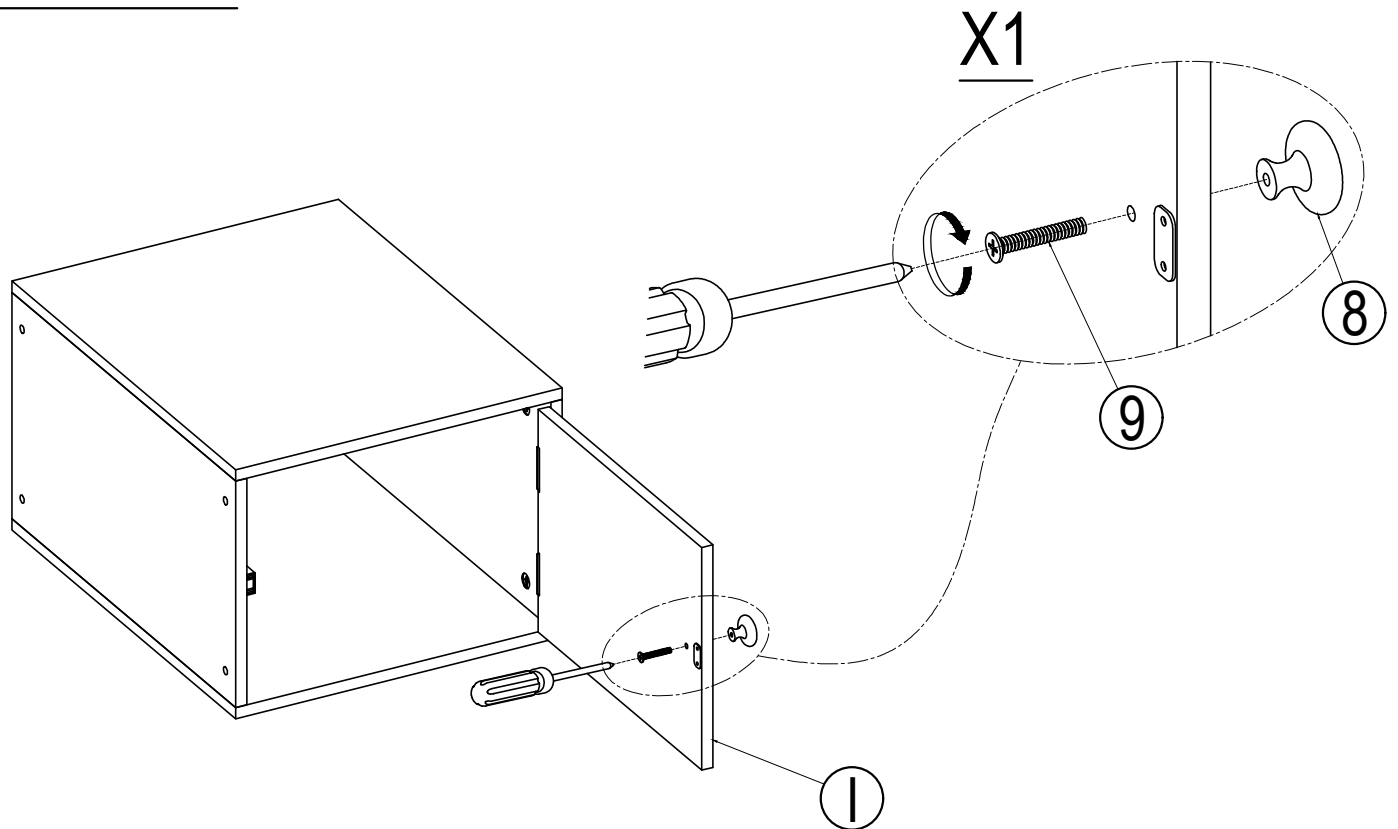

## STEP 5:

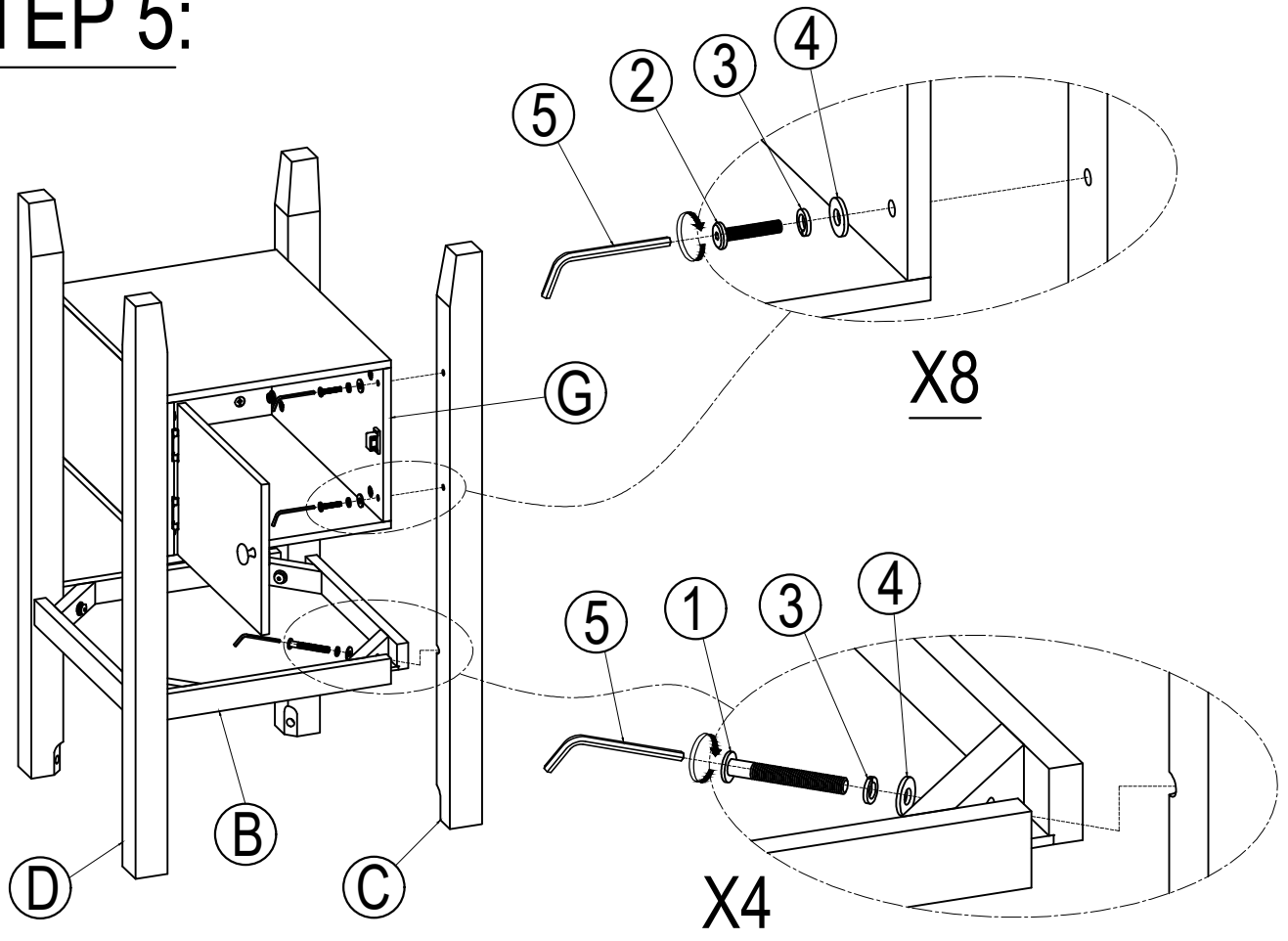

## STEP 6:

